



Professional AC Drive Manufacturer

Edition: Version 2.0 in 2022
Copyright, subject to change without notice.



Professional AC Drive Manufacturer

EC680

Series AC Drive

Quick Guide_{v2.0}



ZHEJIANG EACN ELECTRONIC TECHNOLOGY CO.,LTD

Address: No.1 Jinhe Road, Qinshan Street, Haiyan County, Jiaxing City, Zhejiang Province
Service line: 86-400-166-0573
Website: www.eacn.cn
E-mail: overseas@eacon.cc

TABLE OF CONTENTS

1 Preface.....	1
2 Description of AC drive	2
2.1 Description of the label of AC drive.....	2
2.2 Description of model	2
2.3 Description of serial number.....	2
2.4 Product standard specification.....	3
3 Technical Specifications.....	4
4 Mechanical Dimensions of AC Drive.....	7
5 Main Circuit Connection Functions	9
6 AC Drive Control Terminal Connections	9
7 Operation and Display	10
7.1 LED Operation Panel and pulling components.....	10
7.2 Description of LED operation panel indicators	11
7.3 Description of Keys on the LED Operation Panel.....	11
8 Faults and Solutions.....	11
9 Function Code Table.....	15
9.1 F0 Standard Parameter Group	15
9.2 F1 Motor 1 Parameters	17
9.3 F2 Vector Control Parameters of Motor 1	18
9.4 F3 V/F Control Parameters	19
9.5 F4 Input Terminals	20
9.6 F5 Output Terminals	22
9.7 F6 Start-stop control.....	24
9.8 F7 Operating panel and display	25
9.9 F8 Auxiliary Functions.....	27
9.10 F9 Fault and Protection.....	29
9.11 FA PID Function.....	34
9.12 FB Fixed Length and Count	35
9.13 FC Multi-Reference and Simple PLC Function	35
9.14 FD Communication	38
9.15 FE User-defined Parameters	39
9.16 FP Parameter Management	40
9.17 A0 Torque Control and Limit	41

TABLE OF CONTENTS

9.18 A1 Virtual IO	41
9.19 A2 Motor 2 Parameters	42
9.20 A5 Control Optimization	44
9.21 A6 AI Curve Setting	45
9.22 A7 User Programmable Card	46
9.23 A8 Point-to-point Communication	47
9.24 AI/AO Correction	48
9.25 U0 Monitoring Parameters	49
10 RS485 card and RS485 communication protocol	51
11 Standard wiring diagram	53
12 Warranty Service	55

1. Preface

Thank you for using the EC680 series high-performance current vector control AC drive.

Please carefully read this manual before the installation in order to ensure the correct installation and operation of the AC drive, give full play to its superior performance, and ensure safety. Please keep this guide permanently for future maintenance, service and overhaul.

AC drive is a precise electric and electronic product, thus for the safety of the operators and the equipment, please ensure that the installation and parameters adjustment is done by professional motor engineers and the content marked as “Danger”, “Notice”, etc in this manual must be read carefully. If you have any questions, please contact with the agents of our company, and our technicians are ready to serve you.

The instructions are subject to change, without notice.

You can contact us with any product questions through the following ways.



⚡ Dangerous and wrong use may cause casualties

⚡ Danger

- The power supply must be turned off when laying the wires.
- When the AC power supply is cut off but the indicator light of the manipulator of AC drive is still on, there is still high voltage in the AC drive which is very dangerous, please do not touch the interior circuit and components.
- Do not check the components and signals on the circuit board during operation.
- The terminal of AC drive must be grounded correctly.
- Do not refit or replace the control board and parts without permission, otherwise, there are risks such as electric shock and explosion.

! Wrong use may cause damage to AC drive or mechanical system

! Notice

- Please do not test the voltage resistance of the interior components of AC drive, as the semi-conductor of AC drive is easy to be punctured and damaged by high voltage.
- Never connect the main circuit output terminals U, V, and W directly to the AC main circuit power supply.
- The circuit board of the AC drive has CMOS IC which is extremely easy to be damaged by static electricity, thus please do not touch the circuit board with your hand before taking anti-static electricity measures.
- Only the qualified motor professionals can install the driver, lay the wire, repair and maintain the AC drive.
- The scrapping of AC drive shall be treated as industrial waste and burning is strictly prohibited.

2. Description of AC drive

2.1 Description of the label of AC drive

MODEL:EC6804D0G05D5P43A

① AC drive Model
 ② Input power Spec.
 ③ Output power Spec.
 ④ Barcode
 ⑤ Serial number of production control
 ⑥ Power card versions
 ⑦ Structure version

2.2 Description of Model

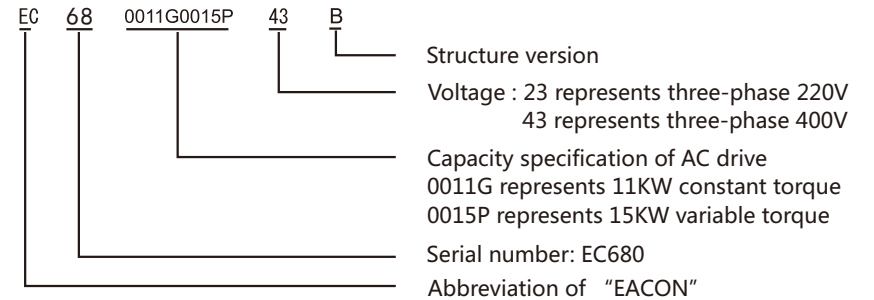

2.3 Description of Serial number

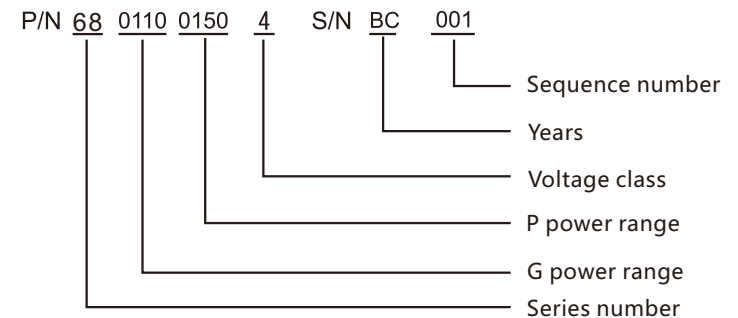

2.4 Product standard specification

Voltage	220V	Voltage	380V
Power (kW)	Rated output current (A)	Power (kW)	Rated output current (A)
0.4	2.1	0.75	3.4
0.75	3.8	1.5	4.8
1.5	7.0	2.2	6.2
2.2	9.0	4.0	11.0
4.0	13.0	5.5	14.0
5.5	25.0	7.5	18.0
7.5	33.0	11	27.0
11	45.0	15	34.0
15	60.0	18.5	41.0
18.5	75.0	22	52.0
22	91.0	30	65.0
30	112.0	37	80.0
		45	96.0
		55	128.0
		75	165.0
		90	185.0
		110	210.0
		132	250.0
		160	307.0
		200	380.0
		220	450.0
		250	480.0
		280	520.0
		315	605.0
		350	670.0
		400	750.0

3. Technical Specifications

Item	Specifications	
Maximum frequency	0.00~320.00Hz 0.00~3200.00Hz (When P0-21=1)	
Carrier frequency	1 - 16 kHz The carrier frequency is automatically adjusted based on the load features.	
Input frequency resolution	Digital setting: 0.01 Hz Analog setting: maximum frequency*0.025%	
Control mode	<ul style="list-style-type: none"> • Sensorless flux vector control (SFVC) • Closed-loop vector control (CLVC) • Voltage/Frequency (V/F) control 	
Startup torque	<ul style="list-style-type: none"> • G type: 0.5 Hz/150% (SFVC); 0 Hz/180% (FVC) • P type: 0.5 Hz/100% 	
Speed range	1:100 (SVC)	1:1000 (FVC)
Speed stability accuracy	± 0.5% (SVC)	± 0.02% (FVC)
Torque control accuracy	± 5% (FVC)	
Overload capacity	<ul style="list-style-type: none"> • G type: 60s for 150% of the rated current, 3s for 180% of the rated current • P type: 60s for 120% of the rated current, 3s for 150% of the rated current 	
Torque boost	Customized boost 0.1% - 30.0%	
V/F curve	<ul style="list-style-type: none"> • Straight-line V/F curve • Multi-point V/F curve • N-power V/F curve (1.2-power, 1.4-power, 1.6-power, 1.8-power, square) 	
V/F separation	Two types: complete separation; half separation	
Ramp mode	<ul style="list-style-type: none"> • Straight-line ramp • S-curve ramp Four groups of acceleration/deceleration time with the range of 0.0 - 6500.0s	
DC braking	DC braking frequency: 0.00 Hz to maximum frequency Braking time: 0.0 - 36.0s Braking action current value: 0.0% - 100.0%	
JOG control	JOG frequency range: 0.00 - 50.00 Hz JOG acceleration/deceleration time: 0.0 - 6500.0s	
Onboard multiple preset speeds	It implements up to 16 speeds via the simple PLC function or combination of DI terminal states.	
Onboard PID	It realizes process-controlled closed loop control system easily.	
Auto voltage regulation (AVR)	It can keep constant output voltage automatically when the mains voltage changes.	
Overvoltage/Overcurrent stall control	The current and voltage are limited automatically during the running process so as to avoid frequent tripping due to over-voltage/over-current.	
High-speed current limiting function	Minimize over-current fault and protect normal operation of AC drive.	

Item		Specifications
	Torque limit and control	It can limit the torque automatically and prevent frequent over current tripping during the running process. Torque control can be implemented in the CLVC mode.
Individualized functions	High performance	Control of asynchronous motor and synchronous motor are implemented through the high-performance current vector control technology.
	Power dip ride through	The load feedback energy compensates the voltage reduction so that the AC drive can continue to run for a short time.
	Rapid current limit	It helps to avoid frequent overcurrent faults of the AC drive.
	Timing control	Time range: 0.0 - 6500.0 minutes
	Multiple communication protocols	It supports communication via Modbus-RTU, PROFIBUSDP, CANlink and CANopen.
	Motor overheat protection	The optional I/O extension card enables AI4 to receive the motor temperature sensor input (PT100, PT1000) so as to realize motor overheat protection.
	Multiple encoder types	It supports various encoders such as differential encoder, open-collector encoder, resolver, UVW encoder, and SIN/COS encoder.
	Advanced background software	It supports the operation of AC drive parameters and virtual oscillograph function, via which the state inside the AC drive is monitored.
RUN	Running command source	<ul style="list-style-type: none"> • Operation panel • Control terminals • Serial communication port You can perform switchover between these sources in various ways.
	Frequency source	There are a total of 10 frequency sources, such as digital setting, analog voltage setting, analog current setting, pulse setting and serial communication port setting. You can perform switchover between these sources in various ways.
	Auxiliary frequency source	There are ten auxiliary frequency sources. It can implement fine tuning of auxiliary frequency and frequency synthesis.
RUN	Input terminal	Standard: 5 digital input (DI) terminals, one of which supports up to 100 kHz high-speed pulse input 2 analog input (AI) terminals, one of which only supports 0-10 V voltage input and the other supports 0-10 V voltage input or 4-20 mA current input Expanding capacity: 5 DI terminals 1 AI terminal that supports -10-10 V voltage input and also supports PT100\PT1000
	Output terminal	Standard 1 high-speed pulse output terminal (open-collector) that supports 0-100 kHz square wave signal output 1 digital output (DO) terminal 1 relay output terminal 1 analog output (AO) terminal that supports 0-20 mA current output or 0-10 V voltage output

Item		Specifications
	Output terminal	Expanding capacity: 1 DO terminal 1 relay output terminal 1 AO terminal that supports 0-20 mA current output or 0-10V voltage output
Display and operation on the operation panel	LED display	It displays the parameters.
	LCD display	Optional, Chinese/English prompt operation content
	Parameters copy	Quick copying of parameters can be realized through LCD operation panel option.
	Key locking and function selection	It can lock the keys partially or completely and define the function range of some keys so as to prevent mis-function.
	Protection mode	Motor short-circuit detection at power-on, input/output phase loss protection, overcurrent protection, over-voltage protection, undervoltage protection, overheat protection and overload protection
	Optional parts	LCD operation panel, braking unit, I/O extension card 1, I/O extension card 2, user programmable card, RS485 communication card, PROFIBUS-DP communication card, CANlink communication card, CANopen communication card, differential input PG card, UVW differential input PG card, resolver PG card and OC input PG card
Environment	Installation location	Indoor, free from direct sunlight, dust, corrosive gas, combustible gas, oil smoke, vapour, drip or salt.
	Altitude	Lower than 1000m
	Ambient temperature	-10° C to +40° C (de-rated if the ambient temperature is between 40° C and 50° C)
	Humidity	Less than 95%RH, without condensing
	Vibration	Less than 5.9m/s (0.6g)
	Storage temperature	-20C ~+60C
	IP level	IP20
Pollution degree	PD2	

4. Mechanical dimension of AC drive

A Structure

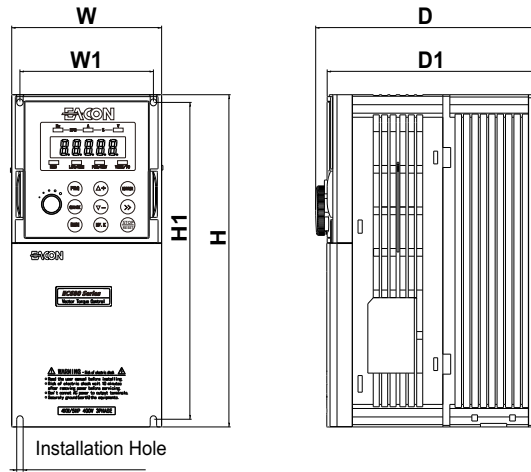

B Structure

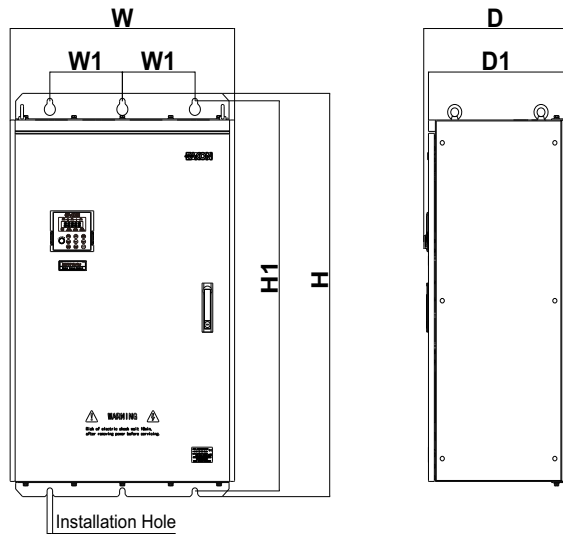

220V Class

Structure	Power (Kw)	W (mm)	W1	H	H1	D	D1	Installation Hole
A Structure	0.4Kw	105	93.5	216	206	156.7	148.8	φ 4.5
	0.75Kw							
	1.5Kw							
	2.2Kw							
	4.0Kw	126	110	260	246	183	173.3	φ 6
	5.5Kw							
	7.5Kw	153	137	341	327	203.3	193.6	φ 7
	11Kw							
	15Kw	180	120	422.2	419.7	203.6	194	φ 9
	18.5Kw							
22Kw	191	120	471	450	241.4	231.6	φ 9	
30Kw								

380V Class

Structure	Power (Kw)	W (mm)	W1	H	H1	D	D1	Installation Hole
A结构	0.75Kw	105	93.5	160	150	136.6	128.7	φ 4.5
	1.5Kw							
	2.2Kw							
	4.0Kw	105	93.5	216	206	156.7	148.8	φ 4.5
	5.5Kw							
	7.5Kw	126	110	260	246	183	173.3	φ 6
	11Kw							
	15Kw	153	137	341	327	203.3	193.6	φ 7
	18.5Kw							
	22Kw	180	120	422.2	419.7	203.6	194	φ 9
30Kw								
37Kw	191	120	471	450	241.4	231.6	φ 9	
45Kw								
B结构	55Kw	300	220	541	516	313.7	300	φ 11
	75Kw							
	90Kw	350	270	730	705	353.7	340	φ 11
	110Kw							
	132Kw	500	180	780	755	353.7	340	φ 11
	160Kw							
	200Kw	650	210	1060	1024	413.7	400	φ 16

7.2 Description of LED operation panel indicators

Indicator	Description	Indicator	Description
RUN	Light off: Stop Light on: Running	LOC/REM	Light off: Panel control Light on: Terminal control
FED/REV	Light off: Running forward Light on: Run in reverse	TUNE/TC	Light off: Normal operation Light on: Torque control mode Slow flash: Tuning status(1 time/sec) Flashing fast: Fault status(1 time/sec)
Hz	Frequency unit	RPM	Speed unit
A	Current unit	%	Percentage
V	Voltage unit		

7.3 Description of Keys on the LED operation panel

Key	Function
PRG	Level 1 menu entry or exit.
ENTER	Enter the menu step by step, set the parameter to confirm.
△+	Increment of data or function code.
▽-	Decrement of data or function code.
>>	In the stop display interface and the running display interface, the display parameters can be selected cyclically. When modifying the parameters, the modification bit of the parameters can be selected.
RUN	Under keyboard operation, used to run the operation.
STOP/RESET	This key can be used to stop and reset operation.
MF. K	According to F7-01, function switch selection can be defined as command source or direction quick switch.
QUICK	Switch between different menu modes according to the value in FP-03.

8. Faults and solutions

Display	Fault name	Possible causes	Solutions
Err01	Inverter unit protection	1: The output circuit is grounded or short circuited. 2: The power cable between the motor and the AC drive is too long. 3: The power module is overheated. 4: The internal connections become loose. 5: The main control board is faulty. 6: The drive board is faulty. 7: The inverter module is faulty.	1: Eliminate external faults. 2: Install a reactor or an output filter. 3: Check the air filter and the cooling fan. 4: Connect all cables properly. 5: Seek technical support. 6: Seek technical support. 7: Seek technical support.
Err02	Overcurrent during acceleration	1: The output circuit is grounded or short circuited. 2: Motor auto-tuning is not performed. 3: The acceleration time is too short.	1: Eliminate external faults. 2: Perform the motor auto-tuning. 3: Increase the acceleration time.

Err02	Overcurrent during acceleration	4: Manual torque boost or V/F curve is not appropriate. 5: The input voltage is too low. 6: The startup operation is performed on the rotating motor. 7: A sudden load is added during acceleration. 8: The AC drive model is of too small power class.	4: Adjust the manual torque boost or V/F curve. 5: Adjust the voltage to the normal range. 6: Select rotational speed tracking restart or start the motor after it stops. 7: Remove the added load. 8: Select an AC drive of higher power class.
Err03	Overcurrent during deceleration	1: The output circuit is grounded or short circuited. 2: Motor auto-tuning is not performed. 3: The deceleration time is too short. 4: The input voltage is too low. 5: A sudden load is added during deceleration. 6: The braking unit and braking resistor are not installed.	1: Eliminate external faults. 2: Perform the motor autotuning. 3: Increase the deceleration time. 4: Adjust the voltage to the normal range. 5: Remove the added load. 6: Install the braking unit and braking resistor.
Err04	Overcurrent at constant speed	1: The output circuit is grounded or short circuited. 2: Motor auto-tuning is not performed. 3: The input voltage is too low. 4: A sudden load is added during operation. 5: The AC drive model is of too small power class.	1: Eliminate external faults. 2: Perform the motor autotuning. 3: Adjust the voltage to the normal range. 4: Remove the added load. 5: Select an AC drive of higher power class.
Err05	Overvoltage during acceleration	1: The input voltage is too high. 2: An external force drives the motor during acceleration. 3: The acceleration time is too short. 4: The braking unit and braking resistor are not installed.	1: Adjust the voltage to normal range. 2: Remove the external force or install a braking resistor. 3: Increase the acceleration time. 4: Install the braking unit and braking resistor.
Err06	Overvoltage during deceleration	1: The input voltage is too high. 2: An external force drives the motor during deceleration. 3: The deceleration time is too short. 4: The braking unit and braking resistor are not installed.	1: Adjust the voltage to normal range. 2: Remove the external force or install a braking resistor. 3: Increase the deceleration time. 4: Install the braking unit and braking resistor.
Err07	Overvoltage at constant speed	1: The input voltage is too high. 2: An external force drives the motor during running.	1: Adjust the voltage to the normal range. 2: Remove the external force or install the braking resistor.
Err08	Control power supply fault	1: The input voltage is not within the allowable range.	1: Adjust the input voltage to the allowable range.
Err09	Undervoltage	1: Instantaneous power failure occurs on the input power supply. 2: The AC drive's input voltage is not within the allowable range. 3: The DC-Bus voltage is abnormal. 4: The rectifier bridge and buffer resistor are faulty.	1: Reset the fault. 2: Adjust the voltage to the normal range. 3: Contact technical support. 4: Contact technical support.

Err09	Undervoltage	5: The drive board is faulty. 6: The main control board is faulty.	5: Contact technical support. 6: Contact technical support.
Err10	AC drive overload	1: The load is too heavy or locked rotor occurs on the motor. 2: The AC drive model is of too small power class.	1: Reduce the load and check the motor and mechanical condition. 2: Select an AC drive of higher power class.
Err11	Motor overload	1: F9-23 is set improperly. 2: The load is too heavy or locked rotor occurs on the motor. 3: The AC drive model is of too small power class.	1: Set it correctly. 2: Reduce the load and check the motor and the mechanical condition. 3: Select an AC drive of higher power class.
Err12	Power input phase loss	1: The three-phase power input is abnormal. 2: The drive board is faulty. 3: The lightening board is faulty. 4: The main control board is faulty.	1: Eliminate external faults. 2: Seek technical support. 3: Seek technical support. 4: Seek technical support.
Err13	Power output phase loss	1: The cable connecting the AC drive and the motor is faulty. 2: The AC drive's three-phase outputs are unbalanced when the motor is running. 3: The drive board is faulty. 4: The module is faulty.	1: Eliminate external faults. 2: Check whether the motor three-phase winding is normal. 3: Seek technical support. 4: Seek technical support.
Err14	Module overheat	1: The ambient temperature is too high. 2: The air filter is blocked. 3: The fan is damaged. 4: The thermally sensitive resistor of the module is damaged. 5: The inverter module is damaged.	1: Lower the ambient temperature. 2: Clean the air filter. 3: Replace the damaged fan. 4: Replace the damaged thermally sensitive resistor. 5: Replace the inverter module.
Err15	External equipment fault	1: External fault signal is input via S.	1: Reset the operation.
Err16	Communication fault	1: The host computer is in abnormal state. 2: The communication cable is faulty. 3: The communication parameters in group PB are set improperly.	1: Check the cabling of host computer. 2: Check the communication cabling. 3: Set the communication parameters properly.
Err17	Contactoer fault	1: The drive board and power supply are faulty. 2: The contactor is faulty.	1: Replace the faulty drive board or power supply board. 2: Replace the faulty contactor.
Err18	Current detection fault	1: The HALL device is faulty. 2: The drive board is faulty.	1: Replace the faulty HALL device. 2: Replace the faulty drive board.
Err19	Motor auto-tuning fault	1: The motor parameters are not set according to the nameplate. 2: The motor auto-tuning times out.	1: Set the motor parameters according to the nameplate properly. 2: Check the cable connecting the AC drive and the motor.
Err20	Encoder fault	1: The encoder type is incorrect. 2: The cable connection of the encoder is incorrect.	1: Set the encoder type correctly based on the actual situation. 2: Eliminate external faults.

Err20	Encoder fault	3: The encoder is damaged. 4: The PG card is faulty.	3: Replace the damaged encoder. 4: Replace the faulty PG card.
Err21	EEPROM readwrite fault	1: The EEPROM chip is damaged.	1: Replace the main control panel.
Err22	AC drive hardware fault	1: Overvoltage exists. 2: Overcurrent exists.	1: Handle based on over-voltage. 2: Handle based on over-current.
Err23	Short circuit to ground	1: The motor is short circuited to the ground.	1: Replace the cable or motor.
Err24	EEPORM Initialization fault	1: Abnormal user data.	1: Reinitialize data and set parameters.
Err26	Running time reached	1: Accumulative running time reaches setting.	1: Clear the record through the parameter initialization function.
Err27	User-defined fault 1	1: The user-defined fault 1 signal is input via DI.	1: Reset the operation.
Err28	User-defined fault 2		
Err29	Power-on time reached	1: Accumulative power-ontime reaches the setting.	1: Clear the record through the parameter initialization function.
Err30	Load becoming 0	1: The AC drive running current is lower than F9-38.	1: Check the load is disconnected or F9-38 and F9-39 is correct.
Err31	PID feedback lost during running	1: The PID feedback is lower than the setting of PA-27.	1: Check the PID feedback signal or set PA-27 to a proper value.
Err40	Pulse-by-pulse current limit fault	1: The load is too heavy or locked rotor occurs on the motor. 2: The AC drive model is of too small power class.	1: Reduce the load and check the motor and mechanical condition. 2: Select the AC drive of higher power class.
Err42	Too large speed deviation	1: The encoder parameters are set incorrectly. 2: The motor auto-tuning is not performed. 3: F9-42 and F9-43 are set incorrectly.	1: Set the encoder parameters properly. 2: Perform the motor autotuning. 3: Set F9-69 and F9-70 correctly based on the actual situation.
Err43	Motor over-speed	1: The encoder parameters are set incorrectly. 2: The motor auto-tuning is not performed. 3: F9-40 and F9-41 are set incorrectly	1: Set the encoder parameters properly. 2: Perform the motor auto-tuning. 3: Set F9-40 and F9-41 correctly based on the actual situation.
Err45	Motor overheat	1: The cabling of the temperature sensor becomes loose. 2: The motor temperature is too high.	1: Check the temperature sensor cabling and eliminate the cabling fault. 2: Lower the carrier frequency or adopt other heat radiation measures.
Err51	Pole position detection failed	1: The deviation between the motor parameters and the actual value is too large.	1: Reconfirm whether the motor parameters are correct, and focus on whether the rated current is set too small.

9. Function Code Table

When FP-00 is set to a non-zero value, the parameter protection password is set. In the function parameter mode and user change parameter mode, the parameter menu can only be entered after correctly entering the password. Set FP-00 to 0 to cancel the password.

The parameter menu in user-defined parameter mode is not password protected.

Group F and group A are basic function parameters, and group u is monitoring function parameters.

☆ : It is possible to modify the parameter with the AC drive in the Stop and in the Run status.

★ : It is not possible to modify the parameter with the AC drive in the Run status.

● : The parameter is the actual measured value and cannot be modified.

*: The parameter is a factory parameter and can be set only by the manufacturer.

F0 Standard Parameter group				
Function Code	Parameter Name	Setting Range	Default	Change
F0-00	AC drive G/P selection	1: G (constant torque load) 2: P (fan and pump)	1	★
F0-01	Motor 1 control mode	0: SVC 2: V/F	2	★
F0-02	Running command selection	0: Operating panel (LED off) 1: Terminal (LED on) 2: Serial communication(LED flashing)	0	☆
F0-03	Main frequency reference setting channel selection	0: Digital setting (revised value is not cleared after power off) 1: Digital setting (revised value is cleared after power off) 2: AI1 3: AI2 4: Keyboard potentiometer 5: Pulse setting (S5) 6: Multi-reference 7: Simple PLC 8: PID reference 9: Communication setting	1	★
F0-04	Auxiliary frequency reference setting channel selection	Same as F0-03 (Main frequency reference setting channel selection)	0	★
F0-05	Base value of range of auxiliary frequency reference for main and auxiliary calculation	0: Relative to maximum frequency 1: Relative to main frequency reference	0	☆
F0-06	Range of auxiliary frequency reference for main and auxiliary calculation	0% to 150%	100%	☆
F0-07	Final Frequency reference setting selection	Ones: Frequency reference selection 0: Main frequency reference 1: Main and auxiliary calculation (based on tens position) 2: Switchover between main and auxiliary 3: Switchover between main and "main & auxiliary calculation" 4: Switchover between auxiliary and "main & auxiliary calculation" 5. Any non-0 value of the main and auxiliary channel is valid, main channel first. Tens: main and auxiliary calculation formula 0: Main + auxiliary 1: Main - auxiliary 2: Max. (main, auxiliary) 3: Min. (main, auxiliary)	00	☆

F0-08	Preset frequency	0.00 Hz to F0-10 (Max. frequency)	50.00 Hz	☆
F0-09	Running direction	0: Run in the default direction 1: Run in the direction reverse to the default direction	0	☆
F0-10	Max. frequency	50.00 Hz to 500.00 Hz	50.00Hz	★
F0-11	Setting channel of frequency upper limit	0: Set by F0-12 1: AI1 2: AI2 3: Keyboard potentiometer 4: PULSE reference (S5) 5: Communication reference	0	★
F0-12	Frequency reference upper limit	Same as F0-03 (Main frequency reference setting channel selection)	50.00Hz	☆
F0-13	Frequency reference upper limit offset	0.00 Hz to F0-10 (Max. frequency)	0.00Hz	☆
F0-14	Frequency reference lower limit	0.00 Hz to F0-12 (Frequency reference upper limit)	0.00Hz	☆
F0-15	Carrier frequency	Model dependent	Model dependent	☆
F0-16	Carrier frequency adjusted with load	0: Disabled 1: Enabled	1	☆
F0-17	Acceleration time 1	0.00s to 650.00s(F0-19 = 2) 0.0s to 6500.0s(F0-19 = 1) 0s to 65000s(F0-19 = 0)	Model dependent	☆
F0-18	Deceleration time 1	0.00s to 650.00s(F0-19 = 2) 0.0s to 6500.0s(F0-19 = 1) 0s to 65000s(F0-19 = 0)	Model dependent	☆
F0-19	Acceleration/Deceleration time unit	0: 1s 1: 0.1s 2: 0.01s	1	★
F0-21	Frequency offset of auxiliary frequency setting channel for main and auxiliary calculation	0.00 Hz to F0-10 (Max. frequency)	0.00 Hz	☆
F0-22	Frequency reference resolution	1: 0.1Hz 2: 0.01 Hz	2	★
F0-23	Retentive of digital setting frequency upon stop	0: Not retentive 1: Retentive	1	☆
F0-24	Motor parameter group selection	0: Motor parameter group 1 1: Motor parameter group 2	0	★
F0-25	Acceleration/Deceleration time base frequency	0: Maximum frequency (F0-10) 1: Frequency reference 2: 100 Hz	0	★
F0-26	Base frequency for UP/ YWN modification during running	0: Running frequency 1: Frequency reference	0	★
F0-27	Running command + frequency source	Ones: operating panel (keypad & display) 0: No function 1: Digital setting 2: AI1 3: AI2 4: Keyboard potentiometer 5: Pulse reference (S5) 6: Multi-reference 7: Simple PLC 8: PID reference 9: Serial communication Tens: terminal control + frequency reference setting channel	0000	☆

F0-27	Running command + frequency source	Hundreds: serial communication + frequency reference setting channel Thousands: automatic operation + frequency reference setting channel	0000	☆
F0-28	Serial port communication protocol	0: Modbus protocol 1: PROFIBUS-DP protocol 2: CAN open protocol	0	★
F1 Motor 1 parameters				
Function Code	Parameter Name	Setting Range	Default	Change
F1-00	Motor type selection	0: Common asynchronous motor 1: Variable frequency asynchronous motor	0	★
F1-01	Motor rated power	0.1kW~1000.0kW	Model dependent	★
F1-02	Motor rated voltage	0.1V~2000V	Model dependent	★
F1-03	Motor rated current	0.01~655.35A (AC Drive<=55kW) 0.1~6553.5A (AC Drive>55kW)	Model dependent	★
F1-04	Motor rated frequency	0.01Hz~maximum frequency	Model dependent	★
F1-05	Motor rated rotational speed	1rpm~65535rpm	Model dependent	★
F1-06	Stator resistance (asynchronous motor)	0.001Ω~65.535Ω (AC Drive<=55kW) 0.0001Ω~6.5535Ω (AC Drive>55kW)	Auto-tuning parameter	★
F1-07	Rotor resistance (asynchronous motor)		Auto-tuning parameter	★
F1-08	Leakage inductive reactance (asynchronous motor)	0.01mH~655.35mH (AC Drive<=55kW) 0.001mH~65.535mH (AC Drive>55kW)	Auto-tuning parameter	★
F1-09	Mutual inductive reactance (asynchronous motor)		Auto-tuning parameter	★
F1-10	No-load current (asynchronous motor)	0.01A~F1-04 (AC Drive<=55kW) 0.1A~F1-04 (AC Drive>55kW)	Auto-tuning parameter	★
F1-27	Encoder harness	1~65535	1024	★
F1-28	Encoder type	0:ABZ Incremental encoder 2:Resolver	0	★
F1-30	ABZ Incremental encoder AB phase sequence	0:Positive 2:Reverse	0	★
F1-34	Number of pole pairs of resolver	1~65535	1	★
F1-36	Speed feedback PG disconnection detection time	0.0s:No action 0.1s~10.0s	0.0s	★
F1-37	Auto-tuning selection	0: No auto-tuning 1: Asynchronous motor partial static auto-tuning 2: Asynchronous motor dynamic auto-tuning 3: Asynchronous motor complete static auto-tuning	0	★

F2 Vector Control Parameters of Motor 1				
Function Code	Parameter Name	Setting Range	Default	Change
F2-00	Speed loop proportional gain 1	1~100	30	☆
F2-01	Speed loop integral time 1	0.01~10.00s	0.50s	☆
F2-02	Switchover frequency 1	0.00~F2-05	5.00Hz	☆
F2-03	Speed loop proportional gain 2	1~100	20	☆
F2-04	Speed loop integral time 2	0.01~10.00s	1.00s	☆
F2-05	Switchover frequency 2	F2-02~maximum frequency	10.00Hz	☆
F2-06	Slip compensation factor	50~200%	100%	☆
F2-07	Time constant of SVC speed loop filter	0.000~0.100s	0.015s	☆
F2-09	Torque upper limit source in speed control mode	0: F2-10 function code setting 1: A11 2: A12 3:Keyboard potentiometer 4: Pulse setting (S5) 5: Communication setting 6: MIN(A11, A12) 7: MAX(A11, A12) The full scale of 1-7 corresponds to F2-10.	0	☆
F2-10	Digital setting of torque upper limit	0.0~200.0%	150.0%	☆
F2-11	Torque limit source in speed control (regenerative)	0: F2-10 (electrical or regenerative) 1: A11 2: A12 3:Keyboard potentiometer 4: Pulse reference 5: Communication reference 6: MIN(A11, A12) 7: MAX(A11, A12) 8: F2-12 The full scale of 1-7 corresponds to F2-12.	0	☆
F2-12	Digital setting of torque limit in speed control (regenerative)	0.0%~200.0%	150.0%	☆
F2-13	Excitation adjustment proportional gain	0~60000	2000	☆
F2-14	Excitation adjustment integral gain	0~60000	1300	☆
F2-15	Torque adjustment proportional gain	0~60000	2000	☆
F2-16	Torque adjustment integral gain	0~60000	1300	☆
F2-17	Speed loop integral separation selection	Units: Integral separation 0: Disabled 1: Enabled	0	☆
F2-21	Max. torque coefficient of field weakening area	50~200%	100%	☆
F2-22	Regenerative power limit selection	0: Disabled 1: Enabled	0	☆

F3 V/F Control Parameters				
Function Code	Parameter Name	Setting Range	Default	Change
F3-00	V/F curve setting	0: Linear V/F 2: Square V/F 3: 1.2-power V/F 4: 1.4-power V/F 6: 1.6-power V/F 8: 1.8-power V/F 9: Reserved 10: V/F complete separation 11: V/F half separation	0	★
F3-01	Torque boost	0.0%: Automatic torque boost 0.1% to 30.0%	Model dependent	☆
F3-02	Cut-off frequency of torque boost	0.00 Hz to the maximum frequency	50.00Hz	★
F3-03	Multi-point V/F frequency point 1	0.00~F3-05	0.00Hz	★
F3-04	Multi-point V/F voltage point 1	0.0~100.0%	0.0%	★
F3-05	Multi-point V/F frequency point 2	F3-03~F3-07	0.00Hz	★
F3-06	Multi-point V/F voltage point 2	0.0~100.0%	0.0%	★
F3-07	Multi-point V/F frequency point 3	F3-05~rated frequency (F1-04)	0.00Hz	★
F3-08	Multi-point V/F voltage point 3	0.0~100.0%	0.0%	★
F3-09	VF slip compensation	0~200.0%	0.0%	★
F3-10	V/F over-excitation gain	0~200	64	☆
F3-11	V/F oscillation suppression gain	0~100	40	☆
F3-13	Voltage source for V/F separation	0: Set by F3-14 1: AI1 2: AI2 3: Keyboard potentiometer 4: Pulse reference (S5) 5: Multi-reference 6: Simple PLC 7: PID reference 8: Communication reference Note: 100.0% corresponds to the rated motor voltage	0	☆
F3-14	Digital setting of voltage for V/F separation	0 V to rated motor voltage	0V	☆
F3-15	Voltage rise time of V/F separation	0.0s to 1000.0s Note: It is the time used for the voltage increases from 0 V to the rated motor voltage.	0.0s	☆
F3-16	Voltage decline time of V/F separation	0.0s to 1000.0s Note: It is the time used for the voltage increases from 0 V to the rated motor voltage.	0.0s	☆
F3-17	Stop mode selection for V/F separation	0: Frequency and voltage declining to 0 independently 1: Frequency declining after voltage declines to 0	0	☆
F3-18	Current limit level	50%~200%	150%	★
F3-19	Current limit selection	0: Disabled 1: Enabled	1(Enabled)	★
F3-20	Current limit gain	0~100	20	☆

F3-21	Compensation factor of speed multiplying current limit	50%~200%	50%	★
F3-22	Voltage limit	650.0V~800.0V	770.0V	★
F3-23	Voltage limit selection	0: Disabled 1: Enabled	1(Enabled)	★
F3-24	Frequency gain for voltage limit	0~100	30	☆
F3-25	Voltage gain for voltage limit	0~100	30	☆
F3-26	Frequency rise threshold during voltage limit	0~50Hz	5Hz	★
F4 Input Terminals				
Function Code	Parameter Name	Setting Range	Default	Change
F4-00	S1 terminal function	0: No function 1: Forward RUN (FWD) or running command 2: Reverse RUN (REV) or running direction (Note: F4-11 must be set when F4-00 is set to 1 or 2.)	1	★
F4-01	S2 terminal function	3: Three-wire control 4: Forward JOG (FJOG) 5: Reverse JOG (RJOG) 6: Terminal UP 7: Terminal YWN 8: Coast to stop 9: Fault reset (RESET) 10: RUN pause 11: External fault normally open (NO) input 12: Multi-reference terminal 1 13: Multi-reference terminal 2 14: Multi-reference terminal 3 15: Multi-reference terminal 4 16: Terminal 1 for acceleration/ deceleration time selection 17: Terminal 2 for acceleration/ deceleration time selection 18: Frequency source switchover 19: UP and YWN setting clear (terminal, operating panel)	4	★
F4-02	S3 terminal function	20: Running command switchover terminal 1 21: Acceleration/Deceleration prohibited 22: PID pause 23: PLC status reset 24: Wobble pause 25: Counter input 26: Counter reset 27: Length count input 28: Length reset 29: Torque control prohibited 30: Pulse input (enabled only for S5) 31: Reserved 32: Immediate DC injection braking 33: External fault normally closed (NC) input 34: Frequency modification enabled 35: PID action direction reverse 36: External STOP terminal 1 37: Running command switchover terminal 2 38: PID integral disabled 39: Switchover between main frequency source and preset frequency 40: Switchover between auxiliary frequency source and preset frequency 41: Motor terminal selection 42: Reserved 43: PID parameter switchover 44: User-defined fault 1 45: User-defined fault 2 46: Speed control/Torque control switchover	9	★
F4-03	S4 terminal function		12	★
F4-04	S5 terminal function		13	★
F4-05	S6 terminal function		0	★
F4-06	S7 terminal function		0	★
F4-07	S8 terminal function		0	★
F4-08	S9 terminal function		0	★

F4-09	S10 terminal function	47: Emergency stop 48: External STOP terminal 2 49: Deceleration DC injection braking 50: Clear the current running time 51: Two-wire/Three-wire mode switchover 52: Reverse frequency forbidden 53-59: Reserved	0	★
F4-10	S filter time	0.000s to 1.000s	0.010s	☆
F4-11	Terminal control mode	0: Two-wire control mode 1 1: Two-wire control mode 2 2: Three-wire control mode 1 3: Three-wire control mode 2	0	★
F4-12	Terminal UP/YWN rate	0.001Hz/s~65.535Hz/s	1.00Hz/s	☆
F4-13	AI curve 1 minimum input	0.00V~F4-15	0.00V	☆
F4-14	AI curve 1 minimum input corresponding setting	-100.0%~+100.0%	0.0%	☆
F4-15	AI curve 1 maximum input	F4-13~+10.00V	10.00V	☆
F4-16	AI curve 1 maximum input corresponding setting	-100.0%~+100.0%	100.0%	☆
F4-17	AI1 filter time	0.00~10.00s	0.10s	☆
F4-18	AI curve 2 minimum input	0.00V~F4-20	0.00V	☆
F4-19	AI curve 2 minimum input corresponding setting	-100.0%~+100.0%	0.0%	☆
F4-20	AI curve 2 maximum input	F4-18~+10.00V	10.00V	☆
F4-21	AI curve 2 maximum input corresponding setting	-100.0%~+100.0%	100.0%	☆
F4-22	AI2 filter time	0.00~10.00s	0.10s	☆
F4-23	AI curve 3 minimum input	-10.00V~F4-25	-10.00V	☆
F4-24	AI curve 3 minimum input corresponding setting	-100.0%~+100.0%	-100.0%	☆
F4-25	AI curve 3 maximum input	F4-23~+10.00V	10.00V	☆
F4-26	AI curve 3 maximum input corresponding setting	-100.0%~+100.0%	100.0%	☆
F4-27	Keyboard potentiometer filter time	0.00s~10.00s	0.10s	☆

F4-28	PULSE minimum input	0.00kHz~F4-30	0.00kHz	☆
F4-29	PULSE minimum input corresponding setting	-100.0%~100.0%	0%	☆
F4-30	PULSE maximum input	F4-28~100.00kHz	50.00kHz	☆
F4-31	PULSE maximum input corresponding setting	-100.0%~100.0%	100.0%	☆
F4-32	PULSE filter time	0.00s~10.00s	0.10s	☆
F4-33	AI curve selection	BIT 0: AI curve selection 1: curve 1 (2 point, check F4-13~F4-16) 2: curve 2 (2 point, check F4-18~F4-21) 3: curve 3 (2 point, check F4-23~F4-26) 4: curve 4 (4 point, check A6-00~A6-07) 5: curve 5 (4 point, check A6-08~A6-15) BIT 1: AI2 curve selection ditto. BIT 2: Keyboard potentiometer curve selection ditto.	321	☆
F4-34	AI below minimum input setting selection	BIT0: AI1 below minimum input setting selection 0: Corresponding to the minimum input setting 1: 0.0% BIT 1: AI2 below minimum input setting selection ditto. BIT 2: Keyboard potentiometer below minimum input setting selection ditto.	000	☆
F4-35	S1 delay time	0.0s~3600.0s	0.0s	★
F4-36	S2 delay time	0.0s~3600.0s	0.0s	★
F4-37	S3 delay time	0.0s~3600.0s	0.0s	★
F4-38	S terminal valid mode selection 1	0: Active high 1: Active low BIT 0: S1 BIT 1: S2 BIT 2: S3 BIT 3: S4 BIT 4: S5	00000	★
F4-39	S terminal valid mode selection 2	0: Active high 1: Active low BIT 0: S6 BIT 1: S7 BIT 2: S8 BIT 3: S9 BIT 4: S10	00000	★
F5 Output Terminals				
Function Code	Parameter Name	Setting Range	Default	Change
F5-00	Y4 output terminal mode selection	0: Pulse output (Y4P) 1: Switch output (Y4R)	0	☆

F5-01	Y4R output function selection	0:No output 1:Inverter is running 2:Fault output (fault for free stop) 3:Frequency level detection FDT1 output 4:Frequency reached 5:Running at zero speed (no output when stopped) 6:Motor overload pre-amarm 7:Inverter overload pre-amarm 8:Set count value reached 9:The specified count value reached 10:Length arrives 11:PLC cycle completed	0	☆
F5-02	Y1 relay function selection	12:Accumulated running time reached 13: Frequency limit 14:Torque limit 15:Ready to run 16:A11>A12 17:Upper limit frequency reached 18:Lower limit frequency reached (operation related)	2	☆
F5-03	Y2 output function selection	19:Brown-out status output 20:Communication settings 21:Positioning complete (reserved) 22:Positioning close (reserved) 23:Running at zero speed 2 (output also when stopped) 24:The cumulative power-on time arrives 25:Frequency detection level FDT2 output 26:Frequency 1 arrives at the output 27:Frequency 2 arrives at the output 28:Current 1 reaches the output 29:Current 1 reaches the output 30:Timed arrival output 31:A11 input timeout 32:Downloading 33:Running in reverse 34:Zero current state 35:Module temperature reached	0	☆
F5-04	Y3 output function selection	36:The output current exceeds the limit 37:The lower limit frequency is reached (it is also output when stopped) 38:Alarm output (all faults) 39:Motor over temperature pre-alarm 40:The running time has arrived 41:Fault output (it is a free stop fault and does not output under voltage)	1	☆
F5-05	Y4 output function selection		4	☆
F5-06	Y4P output function selection	0:Operation frequency 1:Set frequency 2:Output current 3:Output torque(torque absolute value) 4:Output power 5:Output voltage 6:PULSE input(100.0% correspond 100.0kHz) 7:A11 8:A12 9:Keyboard potentiometer 10:Length 11:Count value 12:Communication setting 13:Motor speed	0	☆
F5-07	A01 output function selection		0	☆

F5-08	A02 output function selection	14: Output current (100.0% correspond 1000.0A) 15: Output voltage (100.0% correspond 1000.0V) 16:Output torque (actual torque value)	1	☆
F5-09	Y4P output maximum frequency	0.01kHz~100.00kHz	50.00kHz	☆
F5-10	A01 zero bias factor	-100.0%~+100.0%	0.0%	☆
F5-11	A01 gain	-10.0~+10.0	1.00	☆
F5-12	A02 zero bias factor	-100.0%~+100.0%	0.0%	☆
F5-13	A01 gain	-10.0~+10.0	1.00	☆
F5-17	Y4P output delay time	0.0s~3600.0s	0.0s	☆
F5-18	Y1 output delay time	0.0s~3600.0s	0.0s	☆
F5-20	Y3 output delay time	0.0s~3600.0s	0.0s	☆
F5-21	Y4 output delay time	0.0s~3600.0s	0.0s	☆
F5-22	Y output terminal valid state selection	0:Positive logic BIT 0:Y4R BIT 2:Y2 BIT 4:Y4 1:Inverse logic BIT 1:Y1 BIT 3:Y3	00000	☆
F6 Start-stop control				
Function Code	Parameter Name	Setting Range	Default	Change
F6-00	Start run mode	0:Start and stop directly 1:Speed tracking restart 2:Pre-excitation start (AC asynchronous motor)	0	☆
F6-01	Speed tracking method	0:Start with stop frequency 1:Start from zero speed 2:Start from maximum frequency	0	★
F6-02	Speed tracking speed	1~100	20	☆
F6-03	Start frequency	0.00Hz~10.00Hz	0.00Hz	☆
F6-04	Start frequency hold time	0.0s~100.0s	0.0s	★
F6-05	Start DC braking current/pre-excitation current	0%~100%	0%	★
F6-06	Start DC braking time/pre-excitation time	0.0s~100.0s	0.0s	★

F6-07	Acceleration and deceleration method	0:Linear acceleration time 1、2:Dynamic S-curve acceleration and deceleration	0	★
F6-08	The time ratio of the beginning of the S-curve	0.0%~(100.0%-F6-09)	30%	★
F6-09	The time proportion of the end of the S-curve	0.0%~(100.0%-F6-08)	30%	★
F6-10	Stop mode	0:Decelerate to stop 1:Coast to stop	0	☆
F6-11	DC injection braking start frequency	0.00Hz to the maximum frequency	0.00Hz	☆
F6-12	DC injection braking delay time	0.0s to 100.0s	0.0s	☆
F6-13	DC injection braking level	0% to 100%	0%	☆
F6-14	DC injection braking active time	0.0s to 100.0s	0.0s	☆
F6-15	Braking use ratio	0% to 100%	100%	☆
F6-18	Catching a spinning motor current limit	30% to 200%	Model dependent	★
F6-21	Demagnetization time (effective for SVC)	0.00s to 5.00s	Model dependent	☆
F7 Operating panel and display				
Function Code	Parameter Name	Setting Range	Default	Change
F7-00	Pull out of the keyboard	0:Native keyboard 1:Pull out of the keyboard	0	☆
F7-01	MF.K key function selection	0:MF.K key disabled 1:Switchover from remote control (terminal or communication) to operating panel control 2:Switchover between forward rotation and reverse rotation 3:Forward jog 4:Reverse jog	0	★
F7-02	STOP/RESET key function	0: STOP/RESET key enabled only in operating panel control 1:STOP/RESET key enabled in any operation mode	0	☆
F7-03	LED display running parameters	0000 to FFFF BITO 0:Running frequency 1(Hz) BITO 1:Set frequency (Hz) BITO 2:Bus voltage(V) BITO 3:Output voltage(V) BITO 4:Output current(A) BITO 5:Output power (kW) BITO 6:Output torque 1(%)	1F	☆

F7-03	LED display running parameters	BITO 7:S state BITO 8:Y state BITO 9:A11 voltage(V) BITO 10:A12 voltage(V) BITO 11:Keyboard potentiometer voltage(V) BITO 12:Count value BITO 13:Length value BITO 14:Load speed display BITO 14:PID reference	1F	☆
F7-04	LED display running parameters 2	0000 to FFFF BITO 0:PID feedback BITO 1:PLC stage BITO 2:Pulse reference (kHz) BITO 3:Running frequency 2(Hz) BITO 4:Remaining running time BITO 5:A11 voltage before correction(V) BITO 6:A12 voltage before correction(V) BITO 7:Keyboard potentiometer voltage before correction BITO 8:Linear speed BITO 9:currentpower-on time(h) BITO 10:currentpower running time(Min) BITO 11:Pulse reference(Hz) BITO 12:Communication reference BITO 13:Encoder feedback speed(Hz) BITO 14:Main frequency X display(Hz) BITO 15:Auxiliary frequency Y display(Hz)	0	☆
F7-05	Display stop parameter	0000 to FFFF BITO 0:Frequency reference (Hz) BITO 1:Bus voltage BITO 2:S state BITO 3:Y state BITO 4:A11 voltage(V) BITO 5:A12 voltage(V) BITO 6:Keyboard potentiometer voltage BITO 7:Count value BITO 8:Length value BITO 9:PLC stage BITO 10:Load speed BITO 11:PID reference BITO 12:Pulse reference (kHz)	33	☆
F7-06	Load speed display coefficient	0.0001 to 6.5000	1.0000	☆
F7-07	Inverter module heat sink temperature	-20 C to 120 C	-	●
F7-08	Product number	-	-	●
F7-09	Accumulative running time	0h to 65535h	-	●
F7-10	Performance software version	-	-	●

F7-11	Function software version	-	-	●
F7-12	Number of decimal places for load speed display	BIT0: Number of decimal places for U0-14 0: No decimal places 1: One decimal place 2: Two decimal places BIT1: Number of decimal places for U0-19/ U0-29 1: One decimal place 2: Two decimal places	20	☆
F7-13	Accumulative power on time	0 to 65535h	-	●
F7-14	Accumulative power consumption	0 to 65535kWh	-	●
F8 Auxiliary Functions				
Function Code	Parameter Name	Setting Range	Default	Change
F8-00	Jog frequency reference	0.00Hz to the maximum frequency	2.00Hz	☆
F8-01	Jog acceleration time	0.0s to 6500.0s	20.0s	☆
F8-02	Jog deceleration time	0.0s to 6500.0s	20.0s	☆
F8-03	Acceleration time 2	0.00s to 650.00s (F0-19=2) 0.0s to 6500.0s (F0-19=1) 0s to 65000s (F0-19=0)	Model dependent	☆
F8-04	Deceleration time 2	0.00s to 650.00s (F0-19=2) 0.0s to 6500.0s (F0-19=1) 0s to 65000s (F0-19=0)	Model dependent	☆
F8-05	Acceleration time 3	0.00s to 650.00s (F0-19=2) 0.0s to 6500.0s (F0-19=1) 0s to 65000s (F0-19=0)	Model dependent	☆
F8-06	Deceleration time 3	0.00s to 650.00s (F0-19=2) 0.0s to 6500.0s (F0-19=1) 0s to 65000s (F0-19=0)	Model dependent	☆
F8-07	Acceleration time 4	0.00s to 650.00s (F0-19=2) 0.0s to 6500.0s (F0-19=1) 0s to 65000s (F0-19=0)	0.0s	☆
F8-08	Deceleration time 4	0.00s to 650.00s (F0-19=2) 0.0s to 6500.0s (F0-19=1) 0s to 65000s (F0-19=0)	0.0s	☆
F8-09	Accept data gain (frequency)	-10.00 to 10.00	1.00	☆
F8-10	Frequency jump 2	0.00Hz to the maximum frequency	0.00Hz	☆
F8-11	Frequency jump band	0.00Hz to the maximum frequency	0.00Hz	☆
F8-12	Forward/Reverse run switch over dead-zone time	0.0s to 3000.0s	0.0s	☆
F8-13	Reverse RUN selection	0: Disable 1: Enable	0	☆

F8-14	Running mode when frequency lower than frequency lower limit	0: Run at frequency reference lower limit 1: Stop 2: Run at zero speed	0	☆
F8-15	Droop rate	0.00% to 100.00%	0.00%	☆
F8-16	Accumulative running time threshold	0 to 65000h	0h	☆
F8-17	Accumulative running time threshold	0 to 65000h	0h	☆
F8-18	Startup protection selection	0: Disabled 1: Enabled	0	☆
F8-19	Frequency detection value 1	0.00Hz to the maximum frequency	50.00Hz	☆
F8-20	Frequency detection hysteresis 1	0.0% to 100.0% (FDT1 level)	5.0%	☆
F8-21	Detection width of target frequency reached	0.0% to 100.0% (maximum frequency)	0.0%	☆
F8-22	Jump frequency function	0: Disabled 1: Enabled	0	☆
F8-25	Switch over frequency of acceleration time 1 and acceleration time 2	0.00Hz to the maximum frequency	0.00Hz	☆
F8-26	Switch over frequency of deceleration time 1 and deceleration time 2	0.00Hz to the maximum frequency	0.00Hz	☆
F8-27	Set highest priority to terminal JOG function	0: Disabled 1: Enabled	1	☆
F8-28	Frequency detection value (FDT2)	0.00Hz to the maximum frequency	50.00Hz	☆
F8-29	Frequency detection hysteresis (FDT2)	0.0% to 100.0% (FDT2 level)	5.0%	☆
F8-30	Detection of frequency 1	0.00Hz to the maximum frequency	50.00Hz	☆
F8-31	Detection width of frequency 1	0.0% to 100.0% (maximum frequency)	0.0%	☆
F8-32	Detection of frequency 2	0.00Hz to the maximum frequency	50.00Hz	☆
F8-33	Detection width of frequency 2	0.0% to 100.0% (maximum frequency)	0.0%	☆
F8-34	Zero current detection level	0.0% to 300.0% 100% corresponds to the rated motor current	5.0%	☆
F8-35	Zero current detection delay	0.01s~600.00s	0.10s	☆
F8-36	Output over current threshold	0.0% (no detection) 0.1% to 300.00% (rated motor current)	200.0%	☆
F8-37	Output over current detection delay	0.00s~600.00s	0.00s	☆

F8-38	Detection level of current 1	0.0% to 300.0% (rated motor current)	100.0%	☆
F8-39	Detection width of current 1	0.0% to 300.0% (rated motor current)	0.0%	☆
F8-40	Detection level of current 2	0.0% to 300.0% (rated motor current)	100.0%	☆
F8-41	Detection width of current 2	0.0% to 300.0% (rated motor current)	0.0%	☆
F8-42	Timing function	0:Disabled 1:Enabled	0	★
F8-43	Running time setting channel	0:Set by F8-44(running time) 1:A11 2:A12 3:Keyboard potentiometer (100% of analog input corresponds to the value of F8-44)	0	★
F8-44	Running time	0.0Min to 6500.0Min	0.0Min	★
F8-45	A11 input voltage lower limit	0.00V to F8-46	3.10V	☆
F8-46	A11 input voltage upper limit	F8-45 to 10.00V	6.80V	☆
F8-47	IGBT temperature	0°C to 100°C	75°C	☆
F8-48	Cooling fan working mode	0:Working during running 1:Working continuously	0	☆
F8-49	Wake up frequency	F8-51(hibernating frequency) to F0-10(maximum frequency)	0.00Hz	☆
F8-50	Wake up delay time	0.0s to 6500.0s	0.0s	☆
F8-51	Hibernating frequency	0.00Hz to F8-49(wake up frequency)	0.00Hz	☆
F8-52	Hibernating delay time	0.0s to 6500.0s	0.0s	☆
F8-53	Running time threshold this time	0.0 to 6500.0Min	0Min	☆
F8-54	Output power correction coefficient	0.00% to 200.0%	100.0%	☆
F9 Fault and protection				
Function Code	Parameter Name	Setting Range	Default	Change
F9-00	Motor overload protection	0: Disabled 1:Enabled	1	☆
F9-01	Motor overload protection gain	0.20 to 10.00	1.00	☆
F9-02	Motor overload pre-warning coefficient	50% to 100%	80%	☆
F9-03	Overvoltage protection gain	0 to 100	30	☆
F9-04	Overvoltage protection voltage	650V to 680V	770V	☆

F9-07	Detection of short-circuit to ground	BIT0: Detection of short-circuit to ground upon power on 0:Disabled 1:Enabled BIT1:Detection of short-circuit to ground before running 0:Disabled 1:Enabled	01	☆
F9-08	Braking unit applied voltage	650V to 800V	760V	☆
F9-09	Auto reset times	0 to 20	0	☆
F9-10	Selection of Y action during auto reset	0: Not act 1: Act	0	☆
F9-11	Delay of auto reset	0.1s to 100.0s	1.0s	☆
F9-12	Input phase loss/Contactor protection	BIT0:Input phase loss protection 0:Disabled 1:Enabled BIT1:Contactor protection 0:Disabled 1:Enabled	11	☆
F9-13	Output phase loss protection	BIT0:Output phase loss protection 0:Disabled 1:Enabled BIT1:Contactor protection before running 0:Disabled 1:Enabled	01	☆
F9-14	1st fault type	0: No fault 1: Reserved 2: Overcurrent during acceleration 3: Overcurrent during deceleration 4: Overcurrent at constant speed 5: Overvoltage during acceleration 6: Overvoltage during deceleration 7: Overvoltage at constant speed 8: Pre-charge power fault 9: Undervoltage 10: AC drive overload 11: Motor overload 12: Input phase loss 13: Output phase loss 14: IGBT overheat 15: External fault 16: Communication fault 17: Contactor fault 18: Current detection fault 19: Motor auto-tuning fault 20: Encoder/PG card fault 21: Parameter read and write fault 22: AC drive hardware fault 23: Motor short circuited to ground 24: Reserved 25: Reserved	-	●
F9-15	2nd fault type	26: Accumulative running time reached 27: User-defined fault 1 28: User-defined fault 2 29: Accumulative power-on time reached 30: Load lost 31: PID feedback lost during running 40: Fast current limit timeout 41: Motor switchover error during running 42: Too large speed deviation	-	●
F9-16	3rd (latest) fault type		-	●

F9-16	3rd (latest) fault type	43: Motor over-speed 45: Motor overheat 51: Initial position error 55: Slave error in master-slave control	-	●
F9-17	Frequency upon 3rd (latest) fault	-	-	●
F9-18	Current upon 3rd (latest) fault	-	-	●
F9-19	Bus voltage upon 3rd (latest) fault	-	-	●
F9-20	S state upon 3rd (latest) fault	-	-	●
F9-21	Y state upon 3rd (latest) fault	-	-	●
F9-22	AC drive state upon 3rd (latest) fault	-	-	●
F9-23	Power-on time upon 3rd (latest) fault	-	-	●
F9-24	Running time upon 3rd (latest) fault	-	-	●
F9-27	Frequency upon 2nd fault	-	-	●
F9-28	Current upon 2nd fault	-	-	●
F9-29	Bus voltage upon 2nd fault	-	-	●
F9-30	S state upon 2nd fault	-	-	●
F9-31	Y state upon 2nd fault	-	-	●
F9-32	AC drive state upon 2nd fault	-	-	●
F9-33	Power-on time upon 2nd fault	-	-	●
F9-34	Running time upon 2nd fault	-	-	●
F9-37	Frequency upon 1st fault	-	-	●
F9-38	Current upon 1st fault	-	-	●
F9-39	Bus voltage upon 1st fault	-	-	●

F9-40	S state upon 1st fault	-	-	●
F9-41	Y state upon 1st fault	-	-	●
F9-42	AC drive state upon 1st fault	-	-	●
F9-43	Power-on time upon 1st fault	-	-	●
F9-44	Running time upon 1st fault	-	-	●
F9-47	Fault protection action selection 1	BIT0:Motor overload (Err11) 0: Coast to stop 1: Stop according to the stop mode 2: Continue to run BIT1:Input phase loss (Err12) BIT2:Output phase loss (Err13) BIT3:Thousands: External fault (Err15) BIT4:Communication fault (Err16)	00000	☆
F9-48	Fault protection action selection 2	BIT0:Encoder fault (Err20) 0: Coast to stop BIT1:EEPROM read-write fault (Err21) 0: Coast to stop 1: Stop according to the stop mode BIT2:Reserve BIT3:Motor overheat (Err45) BIT4:Accumulative running time reached(Err26)	00000	☆
F9-49	Fault protection action selection 3	BIT0>User-defined fault 1 (Err27) 0: Coast to stop 1: Stop according to the stop mode 2: Continue to run BIT1>User-defined fault 2 (Err28) 0: Coast to stop 1: Stop according to the stop mode 2: Continue to run BIT2:Accumulative power-on time reached (Err29) 0: Coast to stop 1: Stop according to the stop mode 2: Continue to run BIT3:Load lost (Err30) 0: Coast to stop 1: Deceleration to stop 2: Continue to run at 7% of rated motor frequency and restore to the frequency reference if the load recovers BIT4:PID feedback lost during running (Err31) 0: Coast to stop 1: Stop according to the stop mode 2: Continue to run	00000	☆
F9-50	Fault protection action selection 4	BIT0:Too large speed feedback error(Err42) 0: Coast to stop 1: Stop according to the stop mode 2: Continue to run	0000	☆

F9-50	Fault protection action selection 4	BIT1:Motor overspeed (Err43) BIT2:Initial position fault(Err51)	0000	☆
F9-54	Frequency selection for continuing to run upon fault	0: Current running frequency 1: Frequency reference 2: Frequency upper limit 3: Frequency lower limit 4: Backup frequency upon abnormality	0	☆
F9-55	Backup frequency upon fault	0.0% to 100.0% (100.0% corresponds to F0-10.)	100.0%	☆
F9-56	Type of motor temperature sensor	0: No temperature sensor 2: PT1000	0	☆
F9-57	Motor overheat protection threshold	0°C to 200°C	110°C	☆
F9-58	Motor overheat pro- warning threshold	0°C to 200°C	90°C	☆
F9-59	Power dip ride-through function selection	0: Disabled 1: Bus voltage constant control 2: Decelerate to stop	0	☆
F9-60	Threshold of power dip ride-through function disabled	80% to 100%	85.0%	☆
F9-61	Judging time of bus voltage recovering from power dip	0.0 to 100.0s	0.50s	☆
F9-62	Threshold of power dip ride-through function enabled	60% to 100%	80.0%	☆
F9-63	Load lost protection	0: Disabled 1: Enabled	0	☆
F9-64	Load lost detection level	0.0 to 100.0%	10.0%	☆
F9-65	Load lost detection time	0.0 to 60.0s	1.0s	☆
F9-67	Overspeed detection level	0.0% to 50.0% (maximum frequency)	20.0%	☆
F9-68	Overspeed detection time	0.0s: Not detected 0.1 to 60.0s	1.0s	☆
F9-69	Detection level of speed error	0.0% to 50.0% (maximum frequency)	20.0%	☆
F9-70	Detection time of speed error	0.0s: Not detected 0.1 to 60.0s	5.0s	☆
F9-71	Power dip ride-through gain Kp	0 to 100	40	☆
F9-72	Power dip ride-through integral coefficient Ki	0 to 100	30	☆
F9-73	Deceleration time of power dip ride-through	0 to 300.0s	20.0s	★

FA PID Function				
Function Code	Parameter Name	Setting Range	Default	Change
FA-00	PID reference setting channel	0: Set by FA-01 (PID digital setting) 1: A11 2: A12 3: Keyboard potentiometer 4: Pulse reference (S5) 5: Communication reference 6: Multi-reference	0	☆
FA-01	PID digital setting	0.0% to 100.0%	50.0%	☆
FA-02	PID feedback setting channel	0:A11 1:A12 2:Keyboard potentiometer 3:A11-A12 4:Pulse reference (S5) 5: Communication reference 6: A11 + A12 7: Max. (A11 , A12) 8: Min. (A11 , A12)	0	☆
FA-03	PID operation direction	0: Forward 1: Reverse	0	☆
FA-04	PID reference and feedback range	0 to 65535	1000	☆
FA-05	Proportional gain Kp1	0.0 to 1000.0	20.0	☆
FA-06	Integral time Ti1	0.01s to 10.00s	2.00s	☆
FA-07	Differential time Td1	0.000s to 10.000s	0.000s	☆
FA-08	PID output limit in reverse direction	0.00 Hz to the maximum frequency	0.00Hz	☆
FA-09	PID error limit	0.0% to 100.0%	0.0%	☆
FA-10	PID differential limit	0.00% to 100.00%	0.10%	☆
FA-11	PID reference change time	0.00 to 650.00s	0.00s	☆
FA-12	PID feedback filter time	0.00 to 60.00s	0.00s	☆
FA-13	PID output filter time	0.00 to 60.00s	0.00s	☆
FA-14	Reserved	-	-	☆
FA-15	Proportional gain Kp2	0.0 to 100.0	20.0	☆
FA-16	Integral time Ti2	0.01s to 10.00s	2.00s	☆
FA-17	Differential time Td2	0.000s to 10.000s	0.000s	☆

FA-18	PID parameter switchover condition	0: No switchover 1: Switchover using S 2: Auto switchover based on PID error 3: Auto switchover based on running frequency	0	☆
FA-19	PID error 1 for auto switchover	0.0% to FA-20 (PID error 2 for auto switchover)	20.0%	☆
FA-20	PID error 2 for auto switchover	FA-19 (PID error 1 for auto switchover) to 100.0%	80.0%	☆
FA-21	PID initial value	0.0% to 100.0%	0.0%	☆
FA-22	PID initial value active time	0.00 to 650.00s	0.00s	☆
FA-23	Reserved	-	-	☆
FA-24	Reserved	-	-	☆
FA-25	PID integral property	BIT0: Integral separation 0: Disabled 1: Enabled BIT1: Whether to stop integral operation when the PID output reaches the limit 0: Continue integral operation 1: Stop integral operation	00	☆
FA-26	Detection level of PID feedback loss	0.0%: No detection 0.1% to 100.0%	0.0%	☆
FA-27	Detection time of PID feedback loss	0.0s to 20.0s	0.0s	☆
FA-28	Selection of PID operation at stop	0: Stop and do not operate 1: Compute shutdown	0	☆
FB Fixed Length and Count				
Function Code	Parameter Name	Setting Range	Default	Change
FB-05	Set length	0 m to 65535 m	1000m	☆
FB-06	Actual length	0 m to 65535 m	0m	☆
FB-07	Number of pulses per meter	0.1 to 6553.5	100.0	☆
FB-08	Set count value	1 to 65535	1000	☆
FB-09	Designated count value	1 to 65535	1000	☆
FC Multi-Reference and Simple PLC Function				
Function Code	Parameter Name	Setting Range	Default	Change
FC-00	Reference 0	-100.0% to 100.0%	0.0%	☆
FC-01	Reference 1	-100.0% to 100.0%	0.0%	☆
FC-02	Reference 2	-100.0% to 100.0%	0.0%	☆
FC-03	Reference 3	-100.0% to 100.0%	0.0%	☆
FC-04	Reference 4	-100.0% to 100.0%	0.0%	☆
FC-05	Reference 5	-100.0% to 100.0%	0.0%	☆

FC-06	Reference 6	-100.0% to 100.0%	0.0%	☆
FC-07	Reference 7	-100.0% to 100.0%	0.0%	☆
FC-08	Reference 8	-100.0% to 100.0%	0.0%	☆
FC-09	Reference 9	-100.0% to 100.0%	0.0%	☆
FC-10	Reference 10	-100.0% to 100.0%	0.0%	☆
FC-11	Reference 11	-100.0% to 100.0%	0.0%	☆
FC-12	Reference 12	-100.0% to 100.0%	0.0%	☆
FC-13	Reference 13	-100.0% to 100.0%	0.0%	☆
FC-14	Reference 14	-100.0% to 100.0%	0.0%	☆
FC-15	Reference 15	-100.0% to 100.0%	0.0%	☆
FC-16	Simple PLC running mode	0: Stop after running one cycle 1: Keep final values after running one cycle 2: Repeat after running one cycle	0	☆
FC-17	Simple PLC retentive selection	BIT0: Retentive at power down 0: Not retentive 1: Retentive BIT1: Retentive at stop 0: Not retentive at stop 1: Retentive at stop	00	☆
FC-18	Running time of simple PLC reference 0	0.0s (h) to 6553.5s (h)	0.0s (h)	☆
FC-19	Acceleration/Deceleration time of simple PLC reference 0	0 to 3	0	☆
FC-20	Running time of simple PLC reference 1	0.0s (h) to 6553.5s (h)	0.0s (h)	☆
FC-21	Acceleration/Deceleration time of simple PLC reference 1	0 to 3	0	☆
FC-22	Running time of simple PLC reference 2	0.0s (h) to 6553.5s (h)	0.0s (h)	☆
FC-23	Acceleration/Deceleration time of simple PLC reference 2	0 to 3	0	☆
FC-24	Running time of simple PLC reference 3	0.0s (h) to 6553.5s (h)	0.0s (h)	☆
FC-25	Acceleration/Deceleration time of simple PLC reference 3	0 to 3	0	☆
FC-26	Running time of simple PLC reference 4	0.0s (h) to 6553.5s (h)	0.0s (h)	☆

FC-27	Acceleration/ Deceleration time of simple PLC reference 4	0 to 3	0	☆
FC-28	Running time of simple PLC reference 5	0.0s (h) to 6553.5s (h)	0.0s (h)	☆
FC-29	Acceleration/ Deceleration time of simple PLC reference 4	0 to 3	0	☆
FC-30	Running time of simple PLC reference 6	0.0s (h) to 6553.5s (h)	0.0s (h)	☆
FC-31	Acceleration/ Deceleration time of simple PLC reference 6	0 to 3	0	☆
FC-32	Running time of simple PLC reference 7	0.0s (h) to 6553.5s (h)	0.0s (h)	☆
FC-33	Acceleration/ Deceleration time of simple PLC reference 7	0 to 3	0	☆
FC-34	Running time of simple PLC reference 8	0.0s (h) to 6553.5s (h)	0.0s (h)	☆
FC-35	Acceleration/ Deceleration time of simple PLC reference 8	0 to 3	0	☆
FC-36	Running time of simple PLC reference 9	0.0s (h) to 6553.5s (h)	0.0s (h)	☆
FC-37	Acceleration/ Deceleration time of simple PLC reference 9	0 to 3	0	☆
FC-38	Running time of simple PLC reference 10	0.0s (h) to 6553.5s (h)	0.0s (h)	☆
FC-39	Acceleration/ Deceleration time of simple PLC reference 10	0 to 3	0	☆
FC-40	Running time of simple PLC reference 11	0.0s (h) to 6553.5s (h)	0.0s (h)	☆
FC-41	Acceleration/ Deceleration time of simple PLC reference 11	0 to 3	0	☆

FC-42	Running time of simple PLC reference 12	0.0s (h) to 6553.5s (h)	0.0s (h)	☆
FC-43	Acceleration/ Deceleration time of simple PLC reference 12	0 to 3	0	☆
FC-44	Running time of simple PLC reference 13	0.0s (h) to 6553.5s (h)	0.0s (h)	☆
FC-45	Acceleration/ Deceleration time of simple PLC reference 13	0 to 3	0	☆
FC-46	Running time of simple PLC reference 14	0.0s (h) to 6553.5s (h)	0.0s (h)	☆
FC-47	Acceleration/ Deceleration time of simple PLC reference 14	0 to 3	0	☆
FC-48	Running time of simple PLC reference 15	0.0s (h) to 6553.5s (h)	0.0s (h)	☆
FC-49	Acceleration/ Deceleration time of simple PLC reference 15	0 to 3	0	☆
FC-50	Time unit of simple PLC running	0: s	0	☆
FC-51	Reference 0 source	0: Set by FC-00 (Reference 0) 1: A11 2: A12 3: Keyboard potentiometer 4: Pulse reference 5: PID 6: Set by preset frequency (F0-08), modified using terminal UP/YWN	0	☆
FD Communication				
Function Code	Parameter Name	Setting Range	Default	Change
FD-00	Baud rate	BIT0: MODBUS 0: 300 bps 1: 600 bps 2: 1200 bps 3: 2400 bps 4: 4800 bps 5: 9600 bps 6: 19200 bps 7: 38400 bps 8: 57600 bps 9: 115200 bps BIT1: PROFIBUS-DP 0: 115200 bps 1: 208300 bps 2: 256000 bps 3: 512000 bps BIT2: Reserved	5005	☆

FD-00	Baud rate	BIT3: CANlink 0: 20 1:50 2:100 3:125 4:250 5:500 6:1M	5005	☆
FD-01	Modbus data format symbol	0: No check (8, N, 2) 1: Even parity check (8, E, 1) 2: Odd parity check (8, O, 1) 3: No check, data format (8, N, 1) (Valid for Modbus)	0	☆
FD-02	Local address	0: Broadcast address; 1 to 247 (Valid for Modbus, PROFIBUS-DP, and CANlink)	1	☆
FD-03	Modbus response delay	0 to 20 ms (Valid for Modbus)	2	☆
FD-04	Serial port communication timeout	0.0: Disabled 0.1 to 60.0s(Valid for Modbus, Profibus-DP and CANopen)	0.0	☆
FD-05	Modbus protocol selection and Pro bus-DP data frame	BIT0:Modbus 0: Non-standard Modbus protocol 1: Standard Modbus protocol BIT1:Pro bus-DP 0: PP01 format 1: PP02 format 2: PP03 format 3: PP05 format	31	☆
FD-06	Current resolution read by communication	0: 0.01 A (valid when ≤ 55 kW)	0	☆
FD-08	PRO BUS and CANopen communication detection time	0.0 (Invalid) 0.1 to 60.0s	0	☆
FE User-Defined Parameters				
Function Code	Parameter Name	Setting Range	Default	Change
FE-00	User-defined parameter 0	F0-00 to FP-xx A0-00 to Ax-xx U0-00 to U0-xx U3-00 to U3-xx	U3.17	☆
FE-01	User-defined parameter 1		U3.16	☆
FE-02	User-defined parameter 2		F0.00	☆
FE-03	User-defined parameter 3		F0.00	☆
FE-04	User-defined parameter 4		F0.00	☆
FE-05	User-defined parameter 5		F0.00	☆
FE-06	User-defined parameter 6		F0.00	☆
FE-07	User-defined parameter 7		F0.00	☆
FE-08	User-defined parameter 8		F0.00	☆
FE-09	User-defined parameter 9		F0.00	☆

FE-10	User-defined parameter 10	F0-00 to FP-xx A0-00 to Ax-xx U0-00 to U0-xx U3-00 to U3-xx	F0.00	☆
FE-11	User-defined parameter 11		F0.00	☆
FE-12	User-defined parameter 12		F0.00	☆
FE-13	User-defined parameter 13		F0.00	☆
FE-14	User-defined parameter 14		F0.00	☆
FE-15	User-defined parameter 15		F0.00	☆
FE-16	User-defined parameter 16		F0.00	☆
FE-17	User-defined parameter 17		F0.00	☆
FE-18	User-defined parameter 18		F0.00	☆
FE-19	User-defined parameter 19		F0.00	☆
FE-20	User-defined parameter 20		U0.68	☆
FE-21	User-defined parameter 21		U0.69	☆
FE-22	User-defined parameter 22		F0.00	☆
FE-23	User-defined parameter 23		F0.00	☆
FE-24	User-defined parameter 24		F0.00	☆
FE-25	User-defined parameter 25		F0.00	☆
FE-26	User-defined parameter 26		F0.00	☆
FE-27	User-defined parameter 27		F0.00	☆
FE-28	User-defined parameter 28		F0.00	☆
FE-29	User-defined parameter 29		F0.00	☆
FP Parameter Management				
Function Code	Parameter Name	Setting Range	Default	Change
FP-00	User password	0 to 65535	0	☆
FP-01	Parameter Initialization	0: No operation 01: Restore factory parameters except motor parameters 02: Clear records 04: Back up current user parameters 501: Restore user backup parameters	0	☆

FP-02	Parameter display property	BIT0: Group U 0: Not displayed 1: Displayed BIT1: Group A 0: Not displayed 1: Displayed	11	☆
FP-03	Selection of individualized parameter display	BIT0: Selection of user-defined parameter display 0: Not displayed 1: Displayed BIT1: Selection of user-modified 0: Not displayed 1: Displayed	00	☆
FP-04	Selection of parameter modification	0: Disabled 1: Enabled	0	☆
A0 Torque Control and Limit				
Function Code	Parameter Name	Setting Range	Default	Change
A0-00	Speed/Torque control selection	0: Speed control 1: Torque control	0	★
A0-01	Torque reference source in torque control	0: Set by A0-03 (Torque digital setting in torque control) 1: A11 2: A12 3: Keyboard potentiometer 4: Pulse reference 5: Communication reference 6: Min. (A11, A12) 7: Max. (A11, A12) The full scale of 1-7 corresponds to A0-03.	0	★
A0-03	Torque digital setting in torque control	-200.0% to 200.0%	150.0%	☆
A0-05	Forward max. frequency in torque control	0.00 Hz to the maximum frequency	50.00Hz	☆
A0-06	Reverse max. frequency in torque control	0.00 Hz to the maximum frequency	50.00Hz	☆
A0-07	Acceleration time in torque control	0.00s to 650.00s	0.00s	☆
A0-08	Deceleration time in torque control	0.00s to 650.00s	0.00s	☆
A1 Virtual IO				
Function Code	Parameter Name	Setting Range	Default	Change
A1-00	VS1 function selection	0 to 59	0	★
A1-01	VS2 function selection	0 to 59	0	★
A1-02	VS3 function selection	0 to 59	0	★

A1-03	VS4 function selection	0 to 59	0	★
A1-04	VS5 function selection	0 to 59	0	★
A1-05	VS active state setting mode	0: Decided by state of VYx 1: Decided by A1-06 BIT0:VS1 BIT1:VS2 BIT2:VS3 BIT3:VS4 BIT4:VS5	00000	★
A1-06	Selection of VS active state	0: Disabled 1: Enabled BIT0:VS1 BIT1:VS2 BIT2:VS3 BIT3:VS4 BIT4:VS5	00000	★
A1-07	Function selection for A11 used as S	0 to 59	0	★
A1-08	Function selection for A12 used as S	0 to 59	0	★
A1-09	Function selection for keyboard used as S	0 to 59	0	★
A1-10	Active state selection for AI used as S	0: High level active 1: Low level active BIT0:A11 BIT1:A12 BIT2:Pull out keyboard potentiometer	000	★
A1-11	VY1 function selection	0: Short with physical Sx internally 1 to 41: See physical Y selection in group F5	0	☆
A1-12	VY2 function selection		0	☆
A1-13	VY3 function selection		0	☆
A1-14	VY4 function selection		0	☆
A1-15	VY5 function selection		0	☆
A1-16	VY1 output delay	0.0s to 3600.0s	0.0s	☆
A1-17	VY2 output delay	0.0s to 3600.0s	0.0s	☆
A1-18	VY3 output delay	0.0s to 3600.0s	0.0s	☆
A1-19	VY4 output delay	0.0s to 3600.0s	0.0s	☆
A1-20	VY5 output delay	0.0s to 3600.0s	0.0s	☆
A1-21	VY active mode selection	0: Positive logic active 1: Negative logic active BIT0:VY1 BIT1:VY2 BIT2:VY3 BIT3:VY4 BIT4:VY5	00000	☆
A2 Motor 2 Parameters				
Function Code	Parameter Name	Setting Range	Default	Change
A2-00	Motor type selection	0: Common asynchronous motor 1: Variable frequency asynchronous motor	0	★
A2-01	Rated motor power	0.1 kW to 1000.0 kW	Model dependent	★

A2-02	Rated motor voltage	1 V to 2000 V	Model dependent	★
A2-03	Rated motor current	0.01 A to 655.35 A (AC drive power ≤ 55 kW) 0.1 A to 6553.5 A (AC drive power > 55 kW)	Model dependent	★
A2-04	Rated motor frequency	0.01 Hz to the maximum frequency	Model dependent	★
A2-05	Rated motor speed	1 rpm to 65535 rpm	Model dependent	★
A2-06	Stator resistance	0.001 Ω to 65.535 Ω (AC drive power ≤ 55 kW) 0.0001 Ω to 6.5535 Ω (AC drive power > 55 kW)	Model dependent	★
A2-07	Rotor resistance	0.001 Ω to 65.535 Ω (AC drive power ≤ 55 kW) 0.0001 Ω to 6.5535 Ω (AC drive power > 55 kW)	Model dependent	★
A2-08	Leakage inductive reactance	0.01 mH to 655.35 mH (AC drive power ≤ 55 kW) 0.001 mH to 65.535 mH (AC drive power > 55 kW)	Model dependent	★
A2-09	Mutual inductive reactance	0.1 mH to 6553.5 mH (AC drive power ≤ 55 kW) 0.01 mH to 655.35 mH (AC drive power > 55 kW)	Model dependent	★
A2-10	No-load current	0.01 A to A2-03 (AC drive power ≤ 55 kW) 0.1 A to A2-03 (AC drive power > 55 kW)	Model dependent	★
A2-27	Encoder pulses per revolution	1 to 65535	1024	★
A2-28	Encoder type	0: ABZ incremental encoder 2: Resolver	0	★
A2-29	Speed feedback channel selection	0: Local PG card 1: Extension PG card 2: Pulse input (S5)	0	★
A2-30	A/B phase sequence of ABZ incremental encoder	0: Forward 1: Reverse	0	★
A2-31	Encoder installation angle	0.0 to 359.9°	0.0°	★
A2-34	Number of pole pairs of resolver	1 to 65535	1	★
A2-36	Encoder wire-break fault detection time	0.0s: No detection 0.1s to 10.0s	0.0s	★
A2-37	Auto-tuning selection	0: No auto-tuning 1: Asynchronous motor partial static auto-tuning 2: Asynchronous complete dynamic auto-tuning 3: Asynchronous complete static auto-tuning	0	★
A2-38	Speed loop proportional gain 1	1 to 100	30	☆
A2-39	Speed loop integral time 1	0.01s to 10.00s	0.50s	☆
A2-40	Switchover frequency 1	0.00 to A2-43	5.00Hz	☆
A2-41	Speed loop proportional gain 2	1 to 100	20	☆
A2-42	Speed loop integral time 2	0.01s to 10.00s	1.00	☆
A2-43	Switchover frequency 2	A2-40to the maximum frequency	10.00Hz	☆

A2-44	Vector control slip compensation gain	50% to 200%	100%	☆
A2-45	SVC torque filter constant	0.000s to 0.100s	0.000s	☆
A2-47	Torque limit source in speed control	0: Set by A2-48 1: A11 2: A12 3: Keyboard potentiometer 4: Pulse reference 5: Communication reference 6: Min. (A11, A12) 7: Max. (A11, A12) The full scale of 1-7 corresponds to A2-48.	0	☆
A2-48	Digital setting of torque limit in speed control	0.0% to 200.0%	150.0%	☆
A2-50	Digital setting of torque limit in speed control (regenerative)	0.0% to 200.0%	150.0%	☆
A2-51	Excitation adjustment proportional gain	0 to 20000	2000	☆
A2-52	Excitation adjustment integral gain	0 to 20000	1300	☆
A2-53	Torque adjustment proportional gain	0 to 20000	2000	☆
A2-54	Torque adjustment integral gain	0 to 20000	1300	☆
A2-55	Speed loop integral separation selection	BIT0: Integral separation 0: Disabled 1: Enabled	0	☆
A2-59	Max. torque coefficient of field weakening area	50% to 200%	100%	☆
A2-60	Regenerative power limit selection	0: Disabled 1: Enabled	0	☆
A2-61	Motor 2 control mode	0: SVC 1: FVC 2: V/F control	0	★
A2-62	Motor 2 acceleration/deceleration time selection	0: Same to Motor 1 1: Acceleration/Deceleration time 1 2: Acceleration/Deceleration time 2 3: Acceleration/Deceleration time 3 4: Acceleration/Deceleration time 4	0	☆
A2-63	Motor 2 torque boost	0.0%: Automatic torque boost 0.1% to 30.0%	Model dependent	☆
A2-65	Motor 2 oscillation suppression gain	0 to 100	40	☆
A5 Control Optimization				
Function Code	Parameter Name	Setting Range	Default	Change
A5-00	DPWM switchover frequency upper limit	5.00 Hz to the maximum frequency	8.00Hz	☆

A5-01	PWM modulation pattern	0: Asynchronous modulation 1: Synchronous modulation	0	☆
A5-02	Dead zone compensation mode selection	0: Disabled 1: Enabled (compensation mode 1)	1	☆
A5-03	Random PWM depth	0: Random PWM invalid 1 to 10: Random PWM	0	☆
A5-04	Overcurrent fast prevention	0: Disabled 1: Enabled	1	☆
A5-05	Voltage over modulation coefficient	100 to 110	105	★
A5-06	Undervoltage threshold	210 to 420V	350V	☆
A5-08	Dead-zone time adjustment	100% to 200%	150%	★
A5-09	Mutual inductive reactance	210 to 420V	Model dependent	★
A6 AI Curve Setting				
Function Code	Parameter Name	Setting Range	Default	Change
A6-00	AI curve 4 min. Input	-10.00 V to A6-02	0.00V	☆
A6-01	Corresponding percentage of AI curve 4 min. Input	-100.0% to +100.0%	0.0%	☆
A6-02	AI curve 4 inflection 1 input	A6-00 to A6-04	3.00V	☆
A6-03	Corresponding percentage of AI curve 4 inflection 1 input	-100.0% to +100.0%	30.0%	☆
A6-04	AI curve 4 inflection 2 input	A6-02 to A6-06	6.00V	☆
A6-05	Corresponding percentage of AI curve 4 inflection 2 input	-100.0% to +100.0%	60.0%	☆
A6-06	AI curve 4 max. Input	A6-04 to +10.00V	10.00V	☆
A6-07	Corresponding percentage of AI curve 4 max. Input	-100.0% to +100.0%	100.0%	☆
A6-08	AI curve 5 min. Input	-10.00V to A6-10	-10.00V	☆
A6-09	Corresponding percentage of AI curve 5 min. Input	-100.0% to +100.0%	-100.0%	☆
A6-10	AI curve 5 inflection 1 input	A6-08 to A6-12	-3.00V	☆
A6-11	Corresponding percentage of AI curve 5 inflection 1 input	-100.0% to +100.0%	-30.0%	☆
A6-12	AI curve 5 inflection 2 input	A6-10 to A6-14	3.00V	☆

A6-13	Corresponding percentage of AI curve 5 inflection 2 input	-100.0% to +100.0%	30.0%	☆
A6-14	AI curve 5 max. Input	A6-12 to +10.00V	10.00V	☆
A6-15	Corresponding percentage of AI curve 5 max. Input	-100.0% to +100.0%	100.0%	☆
A6-24	Jump point of AI1 input corresponding setting	-100.0% to +100.0%	0.0%	☆
A6-25	Jump amplitude of AI1 input corresponding setting	0.0% to 100.0%	0.5%	☆
A6-26	Jump point of AI2 input corresponding setting	-100.0% to 100.0%	0.0%	☆
A6-27	Jump amplitude of AI2 input corresponding setting	0.0% to 100.0%	0.5%	☆
A6-28	Keyboard potentiometer to set the jump point	-100.0% to 100.0%	0.0%	☆
A6-29	Keyboard potentiometer to set the jump range	0.0% to 100.0%	0.5%	☆
A7 User Programmable Card				
Function Code	Parameter Name	Setting Range	Default	Change
A7-00	User programmable function selection	0: Disabled 1: Enabled	0	★
A7-01	Control board output terminal control mode selection	0: AC drive control 1: User programmable card control BIT0: Y4R (Y4 used as digital output) BIT1: Relay (Y1A-Y1B-Y1C) BIT2: Y1 BIT3: Y4P (Y4 used as pulse control) BIT4: Ten thousands: A01	0	★
A7-02	Programmable card AI/A0 function selection	0: Keyboard potentiometer (voltage input), A02 (voltage output) 1: Keyboard potentiometer (voltage input), A02 (current output) 2: Keyboard potentiometer (current input), A02 (voltage output) 3: Keyboard potentiometer (current input), A02 (current output) 4: Keyboard potentiometer (PTC input), A02 (voltage output) 5: Keyboard potentiometer (PTC input), A02 (current output) 6: Keyboard potentiometer (PT100 input), A02 (voltage output)	0	★

A7-02	Programmable card AI/AO function selection	7: Keyboard potentiometer (PT100 input), A02 (current output)	0	★
A7-03	Y4P output	0.0% to 100.0%	0.0%	☆
A7-04	A01 output	0.0% to 100.0%	0.0%	☆
A7-05	Selection of PLC program controlling digital output	Binary setting BIT0:Y4R BIT2:Y	000	☆
A7-06	Setting frequency reference using the user programmable card	-100.00% to 100.00%	0.0%	☆
A7-07	Setting torque reference using the user programmable card	-200.0% to 200.0%	0.0%	☆
A7-08	Setting running command using the user programmable card	0: No command 1: Forward run 2: Reverse run 3: Forward jog 4: Reverse jog 5: Coast to stop 6: Decelerate to stop 7: Fault reset	0	☆
A7-09	Setting torque reference with the user programmable card	0: No fault 80 to 89: User-defined fault code	0	☆
A8 Point-to-point Communication				
Function Code	Parameter Name	Setting Range	Default	Change
A8-00	Point-to-point communication	0: Disabled 1: Enabled	0	☆
A8-01	Master or slave selection	0: Master 1: Slave	0	☆
A8-02	Selection of action of the slave in point-to-point communication	BIT0: Whether to follow master's command 0: No 1: Yes BIT1: Whether to send fault information to master when a fault occurs 0: No 1: Yes BIT2: Whether to alarm when it becomes off-line 0: No 1: Yes (Err16)	011	★
A8-03	Slave received data	0: Torque given 1: Frequency given	0	☆
A8-04	Zero offset of received data (torque)	-100.00% to 100.00%	0.00%	★
A8-05	Gain of received data (torque)	-10.00 to 100.00	1.00	★
A8-06	Point-to-point communication interruption detection time	0.0 to 10.0s	1.0s	☆

A8-07	Master data sending cycle in point-to-point communication	0.001 to 10.000s	0.001s	☆
A8-11	Window width	0.20 Hz to 10.00 Hz	0.50Hz	☆
AI/AO Correction				
Function Code	Parameter Name	Setting Range	Default	Change
AC-00	A11 measured voltage 1	-10.00 V to 10.000 V	Factory corrected	☆
AC-01	A11 displayed voltage 1	-10.00 V to 10.000 V	Factory corrected	☆
AC-02	A11 measured voltage 2	-10.00 V to 10.000 V	Factory corrected	☆
AC-03	A11 displayed voltage 2	-10.00 V to 10.000 V	Factory corrected	☆
AC-04	A12 measured voltage 1	-10.00 V to 10.000 V	Factory corrected	☆
AC-05	A12 displayed voltage 1	-10.00 V to 10.000 V	Factory corrected	☆
AC-06	A12 measured voltage 2	-10.00 V to 10.000 V	Factory corrected	☆
AC-07	A12 displayed voltage 2	-10.00 V to 10.000 V	Factory corrected	☆
AC-08	Keyboard potentiometer measured voltage 1	-10.00 V to 10.000 V	Factory corrected	☆
AC-09	Keyboard potentiometer displayed voltage 1	-10.00 V to 10.000 V	Factory corrected	☆
AC-10	Keyboard potentiometer measured voltage 2	-10.00 V to 10.000 V	Factory corrected	☆
AC-11	Keyboard potentiometer displayed voltage 2	-10.00 V to 10.000 V	Factory corrected	☆
AC-12	A01 target voltage 1	-10.00 V to 10.000 V	Factory corrected	☆
AC-13	A01 measured voltage 1	-10.00 V to 10.000 V	Factory corrected	☆
AC-14	A01 target voltage 2	-10.00 V to 10.000 V	Factory corrected	☆
AC-15	A01 measured voltage 2	-10.00 V to 10.000 V	Factory corrected	☆
AC-16	A02 target voltage 1	-10.00 V to 10.000 V	Factory corrected	☆
AC-17	A02 measured voltage 1	-10.00 V to 10.000 V	Factory corrected	☆
AC-18	A02 target voltage 2	-10.00 V to 10.000 V	Factory corrected	☆
AC-19	A02 measured voltage 2	-10.00 V to 10.000 V	Factory corrected	☆

U0 Monitoring Parameters			
Function Code	Parameter Name	Minimum Unit	Change
U0-00	Running frequency	0.01Hz	7000H
U0-01	Frequency reference	0.01Hz	7001H
U0-02	Bus voltage	0.1V	7002H
U0-03	Output voltage	1V	7003H
U0-04	Output current	0.01A	7004H
U0-05	Output power	0.1kW	7005H
U0-06	Output torque	0.1%	7006H
U0-07	S state	1	7007H
U0-08	Y state	1	7008H
U0-09	AI1 voltage	0.01V	7009H
U0-10	AI2 voltage (V)/current (mA)	0.01V/0.01mA	700AH
U0-11	Keyboard potentiometer voltage	0.01V	700BH
U0-12	Count value	1	700CH
U0-13	Length value	1	700DH
U0-14	Load speed display	Determined by F7-12 bit0	700EH
U0-15	PID reference	1	700FH
U0-16	PID feedback	1	7010H
U0-17	PLC stage	1	7011H
U0-18	Pulse reference	0.01kHz	7012H
U0-19	Feedback speed	0.01Hz	7013H
U0-20	Remaining running time	0.1Min	7014H
U0-21	AI1 voltage before correction	0.001V	7015H
U0-22	AI2 voltage (V)/current (mA) before correction	0.001V/0.01mA	7016H
U0-23	Keyboard potentiometer voltage before correction	0.001V	7017H
U0-24	Motor speed	1RPM	7018H
U0-25	Current power-on time	1Min	7019H
U0-26	Current running time	0.1Min	701AH
U0-27	Pulse reference	1Hz	701BH
U0-28	Communication reference	0.01%	701CH
U0-29	Encoder feedback speed	0.01Hz	701DH
U0-30	Main frequency reference X display	0.01Hz	701EH
U0-31	Auxiliary frequency reference Y display	0.01Hz	701FH
U0-32	Viewing any register address value	1	7020H
U0-34	Motor temperature	1°C	7022H
U0-35	Target torque	0.1%	7023H
U0-36	Resolver position	1	7024H
U0-37	Power factor angle	0.1°	7025H
U0-38	ABZ position	1	7026H

U0-39	Target voltage upon V/F separation	1V	7027H
U0-40	Output voltage upon V/F separation	1V	7028H
U0-41	S state display	1	7029H
U0-42	Y state display	1	702AH
U0-43	S set for function state display 1 (function 01-40)	1	702BH
U0-44	S set for function state display 2 (function 41-80)	1	702CH
U0-45	Fault information	1	702DH
U0-58	Phase Z counting	1	703AH
U0-59	Rated frequency	0.01%	703BH
U0-60	Running frequency	0.01%	703CH
U0-61	AC drive state	1	703DH
U0-62	Current fault code	1	703EH
U0-63	Sending torque value of point-to-point communication	0.01%	703FH
U0-64	Number of slaves	1	7040H
U0-65	Torque upper limit	0.1%	7041H
U0-66	Communication extension card type	100: CANOpen 200: Pro bus-DP 300: CANLink	7042H
U0-67	Communication extension card version	Display range	-
U0-68	AC drive state on DP card	BIT0: AC drive running status BIT1: Running direction BIT2: Whether the AC drive has a fault BIT3: Target frequency reached BIT4 to BIT7: Reserved BIT8 to BIT15: Fault code	7043H
U0-69	Speed of transmitting DP/0.01 Hz	0.00Hz to Max. frequency	7044H
U0-70	Motor speed of transmitting DP/RMP	0 to rated motor speed	7045H
U0-71	Communication card current display	Display range	-
U0-72	Communication card faulty state	Display range	-
U0-73	Motor SN	0: Motor 1 1: Motor 2	7046H
U0-74	AC drive output torque	0.1%	7047H

10. RS485 card and RS485 communication protocol

Address Definition of Communication Parameters

This part is the content of communication, which is used to control the operation of the inverter, the status of the inverter and the setting of related parameters. Read and write function code parameters (some function codes cannot be changed, only for manufacturers to use or monitor): function code parameter address marking rules.

The rules are represented by the function code group number and label as the parameter address:

High byte: F0~FF (group F), A0~AF (group A), 70~7F (group U) low byte: 00~FF

For example: F0-16, the communication address is F010H; among them, FOH represents the parameters of the F0 group, and 10H represents the value of the serial number 16 in the function group converted to hexadecimal; Note: Group F: neither can read parameters nor change parameters; Group U: can only read, can not change parameters.

Some parameters cannot be changed when the inverter is in the running state; some parameters cannot be changed regardless of the state of the inverter; when changing the function code parameters, pay attention to the range, unit, and related instructions of the parameters.

In addition, because the EEPROM is frequently stored, the service life of the EEPROM will be reduced. Therefore, some function codes do not need to be stored in the communication mode, but only need to change the value in the RAM.

E.g: The function code F3-12 is not stored in the EEPROM, and the address is expressed as F30C; the function code A0-05 is not stored in the EEPROM, and the address is expressed as A005; This address indicates that it can only be used for writing to RAM, but not for reading. When reading, it is an invalid address. For all parameters, command code 07H can also be used to implement this function.

MODBUS frequency command write (write only):

Command address	Command function
1000	*Communication setting value (-10000~10000) (decimal)

Notice:

The communication setting value is a percentage of the relative value, 10000 corresponds to 100.00%, -10000 corresponds to -100.00%. For frequency-dimensioned data, the percent-age is relative to the maximum frequency (F0-10).

Control command input to inverter: (write only)

Command address	Command function
2000	0001: Forward running
	0002: Reverse operation
	0003: Forward jog
	0004: reverse jog
	0005: Coast to stop
	0006: Decelerate to stop
	0007: Fault reset

Digital output terminal control: (write only)

Command address	Command function
2001	BIT0: Y1 output control BIT1: Y2 output control BIT2: RELAY1 output control BIT3: RELAY2 output control BIT4: Y4R output control BIT5: VY1 BIT7: VY3 BIT9: VY5 BIT6: VY2 BIT8: VY4

Address Definition of Communication Parameters

The monitoring parameter address of group U is defined as follows: U0~UF, the high eight bits of the communication address are 70~7F, and the low eight bits are the value of the serial number of the monitoring parameter in the group converted into hexadecimal data, for example: U0-11, Its mailing address is 700BH.

When reading the fault description of the inverter by communication, the communication address is fixed at 8000H. The host computer can obtain the current fault code of the inverter by reading the address data. For the description of the fault code, see the parameter definition of F9-14 in "Appendix C Function Parameter Table".

When reading the running state of the inverter, the communication address is fixed at 3000H, and the host computer can read the address data to Obtain the current inverter running status information, and the definition of the read status word is as follows: 1: Forward running; 2: Reverse running; 3: Stop.

Read drive status: (read only)

Command address	Command function
3000	0001: Forward running
	0002: Reverse operation
	0003: Stop

11. Standard wiring diagram

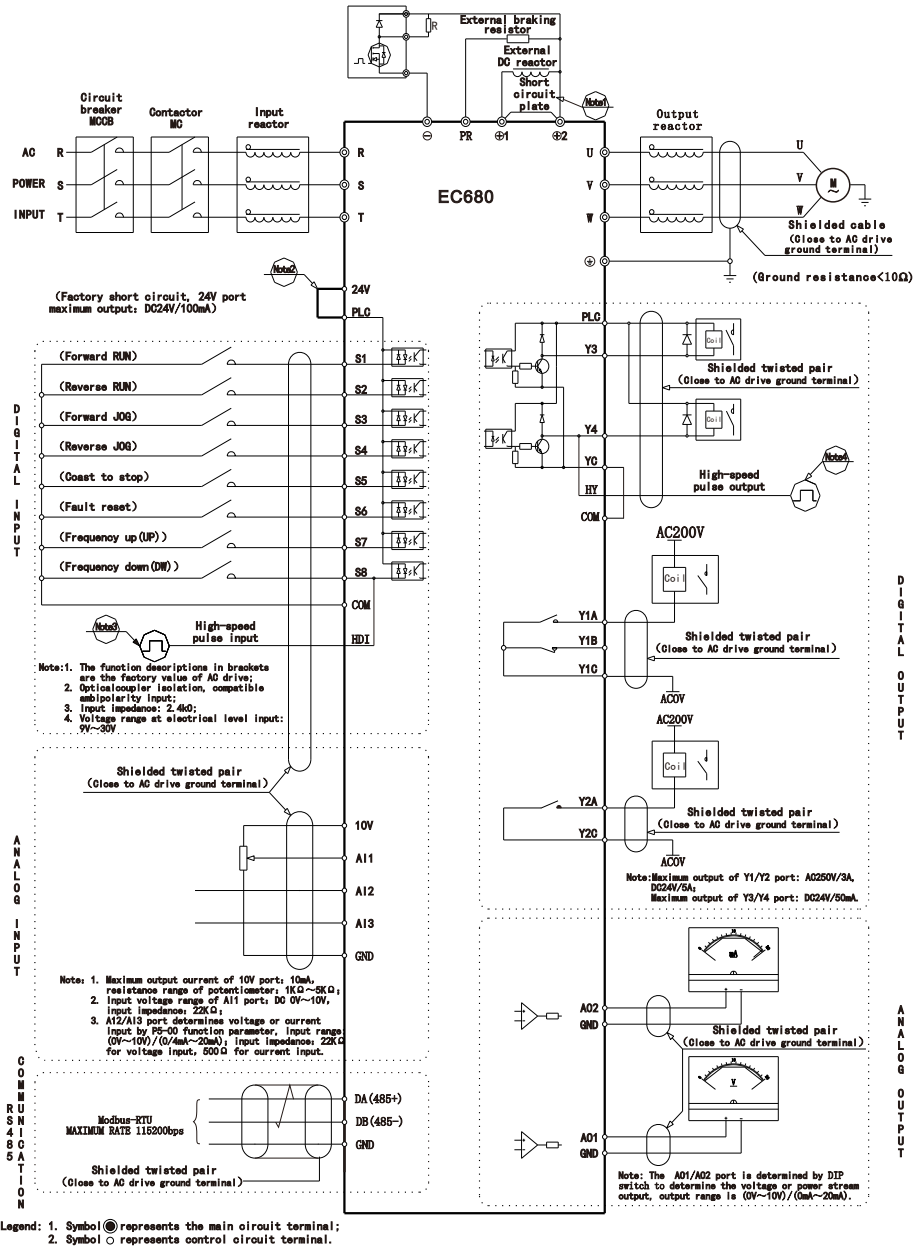

Note:

1. When installing DC reactor, be sure to remove the short connector between terminals ⊕1 and ⊕2; 45kW and below structure without ⊕2 terminal.
2. No PR terminal for 55kW and above.
3. The internal power supply (24V port) or external power supply (PLC port) can be selected for S1~S8 port bias voltage, and the factory value 24V port and PLC port are short circuited;
4. Port S5 is restricted by function parameter F4-04, which can be used as high-speed pulse input channel with maximum input frequency of 50KHz;
5. Port Y4 is restricted by function parameter P5-00, which can be used as high-speed pulse input channel with maximum input frequency of 50KHz.
6. Dial switch foot position corresponds to the legend:



12. Warranty Service



Manufacturer of high quality inverter

Warranty Card

User Name			
User Address			
User Contact		Tel	
Specification		Number	
Distributor			
Contacts		Date of delivery	

ZHE JIANG EACN ELECTRONIC TECHNOLOGY CO.,LTD.

Address: No.1 Jinhe Road, Qinshan Street, Haiyan County, Jiaxing City, Zhejiang Province .

Website: www.eacon.cn

E-mail: overseas@eacon.cc