



Professional AC Drive Manufacturer

Edition: Version 2.1 in 2022

Copyright, subject to change without notice.



Professional AC Drive Manufacturer

EC6000

Series AC Drive

Quick Guide^{V2.1}



ZHEJIANG EACN ELECTRONIC TECHNOLOGY CO.,LTD

Address: No.1 Jinhe Road, Qinshan Street, Haiyan County, Jiaxing City, Zhejiang Province

Service line: 86-400-166-0573

Website: www.eacn.cn

E-mail: overseas@eacon.cc

TABLE OF CONTENTS

1 Preface	1
2 Description of AC drive	2
2.1 Description of the label of AC drive	2
2.2 Description of model	2
2.3 Description of serial number	2
2.4 Product standard specification	3
3 Technical Specifications	4
4 Mechanical Dimensions of AC Drive	7
5 Main Circuit Connection Functions	9
6 AC Drive Control Terminal Connections	9
7 Operation and Display	10
7.1 LED Operation Panel	10
7.2 Description of LED Operation Panel Indicators	11
7.3 Description of Keys on the LED Operation Panel	11
8 Faults and Solutions	11
9 Function Code Table	15
9.1 P0 Standard Parameter Group	15
9.2 P1 Motor Parameters	17
9.3 P2 Vector Control Parameters	18
9.4 P3 V/F Control Parameters	20
9.5 P4 Input Terminals Function	22
9.6 P5 Analog Terminal Parameters	25
9.7 P6 Start/Stop Control Parameters	27
9.8 P7 System Configuration Parameters	28
9.9 P8 Auxiliary Functions	30
9.10 P9 Fault and Protection Parameters	32
9.11 PA Process PID Control Parameters	36
9.12 PB Communication Control Function Parameters	39
9.13 PC Optimization Parameters	40
9.14 PD Internal Control PLC Function and Frequency Parameters	41
9.15 PF User-defined Parameters	45
9.16 A0 Torque Control Parameters	45
9.17 AI Constant Pressure Water Supply Parameters	46
9.18 U Monitoring Parameters	48
10 Standard Wiring Diagram	50
11 Warranty Service	52

1. Preface

V1.0

Thank you for using the EG6000 series high-performance current vector control AC drive. Please carefully read this manual before the installation in order to ensure the correct installation and operation of the AC drive, give full play to its superior performance, and ensure safety. Please keep this guide permanently for future maintenance, service and overhaul.

AC drive is a precise electric and electronic product, thus for the safety of the operators and the equipment, please ensure that the installation and parameters adjustment is done by professional motor engineers and the content marked as “Danger”, “Notice”, etc in this manual must be read carefully. If you have any questions, please contact with the agents of our company, and our technicians are ready to serve you.

The instructions are subject to change, without notice.

You can contact us with any product questions through the following ways.



E-mail
overseas@eacon.cc



Official website
www.eacon.cc



EACON WeChat
Subscription

⚠ Dangerous and wrong use may cause casualties

⚠ Danger

- The power supply must be turned off when laying the wires.
- When the AC power supply is cut off but the indicator light of the manipulator of AC drive is still on, there is still high voltage in the AC drive which is very dangerous, please do not touch the interior circuit and components.
- Do not check the components and signals on the circuit board during operation.
- The terminal of AC drive must be grounded correctly.
- Do not refit or replace the control board and parts without permission, otherwise, there are risks such as electric shock and explosion.

! Wrong use may cause damage to AC drive or mechanical system

! Notice

- Please do not test the voltage resistance of the interior components of AC drive, as the semi-conductor of AC drive is easy to be punctured and damaged by high voltage.
- Never connect the main circuit output terminals U, V, and W directly to the AC main circuit power supply.
- The circuit board of the AC drive has CMOS IC which is extremely easy to be damaged by static electricity, thus please do not touch the circuit board with your hand before taking anti-static electricity measures.
- Only the qualified motor professionals can install the driver, lay the wire, repair and maintain the AC drive.
- The scrapping of AC drive shall be treated as industrial waste and burning is strictly prohibited.

2. Description of AC drive

2.1 Description of the label of AC drive

MODEL:EC604D0G05D5P43A

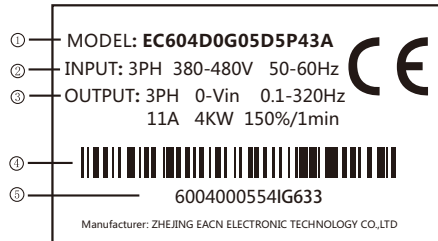

- ① AC drive Model
- ② Input power Spec.
- ③ Output power Spec.
- ④ Barcode
- ⑤ Serial number of production control

2.2 Description of Model

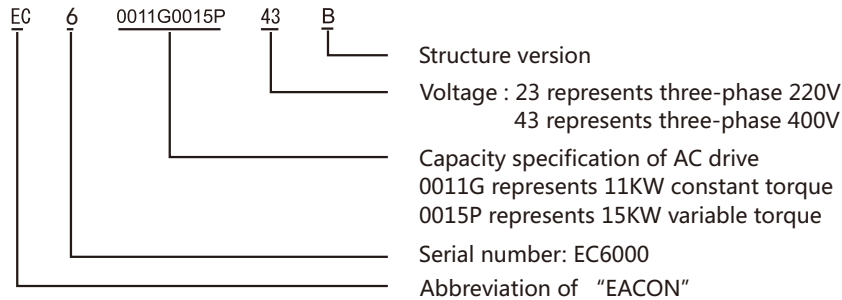

2.3 Description of Serial number

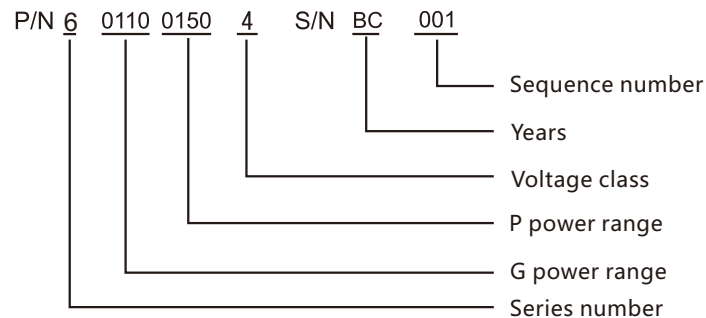

2.4 Product standard specification

Voltage	220V	Voltage	380V
Power (Kw)	Rated output current (A)	Power (Kw)	Rated output current (A)
0.4	2.1	0.75	3.4
0.75	3.8	1.5	4.8
1.5	7.0	2.2	6.2
2.2	9.0	4.0	11.0
4.0	13.0	5.5	14.0
5.5	25.0	7.5	18.0
7.5	33.0	11	27.0
11	45.0	15	34.0
15	60.0	18.5	41.0
18.5	75.0	22	52.0
22	91.0	30	65.0
30	112.0	37	80.0
		45	96.0
		55	128.0
		75	165.0
		90	185.0
		110	210.0
		132	250.0
		160	307.0
		200	380.0
		220	450.0
		250	480.0
		280	520.0
		315	605.0
		350	670.0
		400	750.0

3. Technical Specifications

Item		Specifications		
Standard functions	Maximum frequency	<ul style="list-style-type: none"> • Vector control: 0 - 300 Hz • V/F control: 0 - 320 Hz 		
	Carrier frequency	1 - 16 kHz The carrier frequency is automatically adjusted based on the load features.		
	Input frequency resolution	Digital setting: 0.01 Hz Analog setting: maximum frequency x 0.025%		
	Control mode	<ul style="list-style-type: none"> • Sensorless flux vector control (SFVC) • Closed-loop vector control (CLVC) • Voltage/Frequency (V/F) control 		
	Startup torque	<ul style="list-style-type: none"> • G type: 0.5 Hz/150% (SFVC); 0 Hz/180% (CLVC) • P type: 0.5 Hz/100% 		
	Speed range	1:100(SVC)	1:1000(FVC)	
	Speed stability accuracy	± 0.5% (SVC)	± 0.02% (FVC)	
	Torque control accuracy	± 5% (FVC)		
	Overload capacity	<ul style="list-style-type: none"> • G type: 60s for 150% of the rated current, 3s for 180% of the rated current • P type: 60s for 120% of the rated current, 3s for 150% of the rated current 		
	Torque boost	Customized boost 0.1% - 30.0%		
	V/F curve	<ul style="list-style-type: none"> • Straight-line V/F curve • Multi-point V/F curve • N-power V/F curve (1.2-power, 1.4-power, 1.6-power, 1.8-power, square) 		
	V/F separation	Two types: complete separation; half separation		
	Ramp mode	<ul style="list-style-type: none"> • Straight-line ramp • S-curve ramp Four groups of acceleration/deceleration time with the range of 0.0 - 6500.0s		
	DC braking	DC braking frequency: 0.00 Hz to maximum frequency Braking time: 0.0 - 600.0s Braking action current value: 0.0% - 150.0%		
	JOG control	JOG frequency range: 0.00 - 50.00 Hz JOG acceleration/deceleration time: 0.0 - 6500.0s		
	Onboard multiple preset speeds	It implements up to 16 speeds via the simple PLC function or combination of S terminal states.		
	Onboard PID	It realizes process-controlled closed loop control system easily.		
	Auto voltage regulation (AVR)	It can keep constant output voltage automatically when the mains voltage changes.		
	Overvoltage/Overcurrent stall control	The current and voltage are limited automatically during the running process so as to avoid frequent tripping due to overvoltage/overcurrent.		
	High-speed current limiting function	Minimize over-current fault and protect normal operation of AC drive.		

Item		Specifications
Individualized functions	Torque limit and control	It can limit the torque automatically and prevent frequent over current tripping during the running process. Torque control can be implemented in the CLVC mode.
	High performance	Control of asynchronous motor and synchronous motor are implemented through the high-performance current vector control technology.
	Power dip ride through	The load feedback energy compensates the voltage reduction so that the AC drive can continue to run for a short time.
	Rapid current limit	It helps to avoid frequent overcurrent faults of the AC drive.
	Timing control	Time range: 0.0 - 6500.0 minutes
	Multiple communication protocols	It supports communication via Modbus-RTU, PROFIBUSDP, CANlink and CANopen.
	Motor overheat protection	The optional I/O extension card enables AI4 to receive the motor temperature sensor input (PT100, PT1000) so as to realize motor overheat protection.
	Multiple encoder types	It supports various encoders such as differential encoder, open-collector encoder, resolver, U/VW encoder, and SIN/COS encoder.
	Advanced background software	It supports the operation of AC drive parameters and virtual oscillograph function, via which the state inside the AC drive is monitored.
	RUN	Running command source
Frequency source		There are a total of 10 frequency sources, such as digital setting, analog voltage setting, analog current setting, pulse setting and serial communication port setting. You can perform switchover between these sources in various ways.
Auxiliary frequency source		There are ten auxiliary frequency sources. It can implement fine tuning of auxiliary frequency and frequency synthesis.
Input terminal		Standard: 8 digital input (S) terminals, one of which supports up to 50kHz high-speed pulse input 3 analog input (AI) terminals, two of which only supports 0 - 10 V voltage input and the other supports 0 - 10 V voltage input or 0 - 20 mA current input
Output terminal		Standard 1 high-speed pulse output terminal (open-collector) that supports 0 - 50 kHz square wave signal output 2 digital output (Y) terminal 2 relay output terminal 2 analog output (AO) terminal that supports 0 - 20 mA current output or 0 - 10 V voltage output
LED display		It displays the parameters.
LCD display	Optional, Chinese/English prompt operation content	

	Item	Specifications
Display and operation on the operation panel	LED display	It displays the parameters.
	LCD display	Optional, Chinese/English prompt operation content
	Parameters copy	Quick copying of parameters can be realized through LCD operation panel option.
	Key locking and function selection	It can lock the keys partially or completely and define the function range of some keys so as to prevent mis-function.
Protection mode	Protection mode	Motor short-circuit detection at power-on, input/output phase loss protection, overcurrent protection, over-voltage protection, undervoltage protection, overheat protection and overload protection
Optional parts	Optional parts	LCD operation panel, braking unit, I/O extension card 1, I/O extension card 2, user programmable card, RS485 communication card, PROFIBUS-DP communication card, CANlink communication card, CANopen communication card, differential input PG card, UVW differential input PG card, resolver PG card and OC input PG card
Environment	Installation location	Indoor, free from direct sunlight, dust, corrosive gas, combustible gas, oil smoke, vapour, drip or salt.
	Altitude	Lower than 1000m
	Ambient temperature	-10° C to +40° C (de-rated if the ambient temperature is between 40° C and 50° C)
	Humidity	Less than 95%RH, without condensing
	Vibration	Less than 5.9m/s (0.6g)
	Storage temperature	-20°C ~+60°C
	IP level	IP20
Pollution degree	PD2	

4. Mechanical dimension of AC drive

A Structure

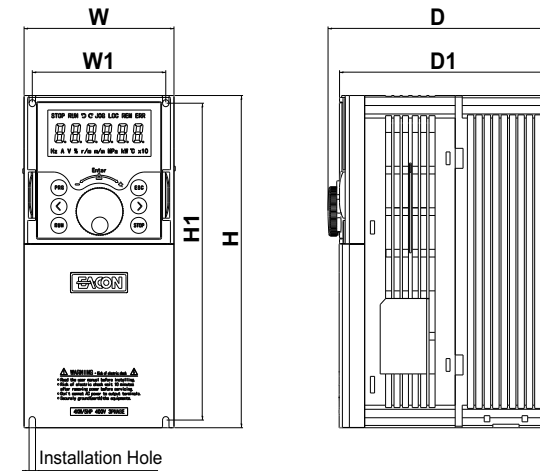

B Structure

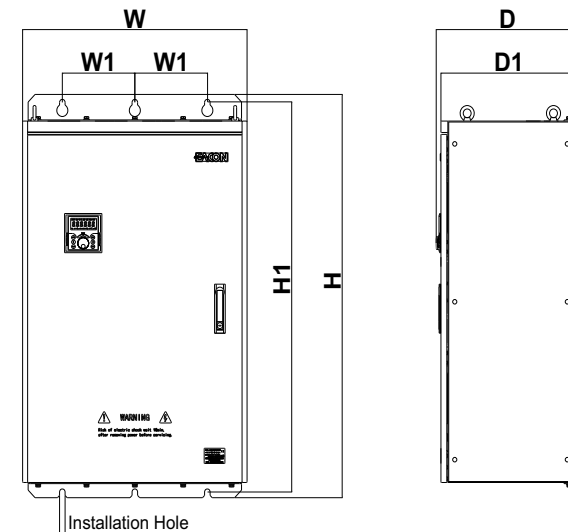

220V Class

Structure	Power (Kw)	W (mm)	W1	H	H1	D	D1	Installation Hole
A Structure	0.75Kw	105	93.5	216	206	156.7	148.8	φ 4.5
	1.5Kw							
	2.2Kw							
	4.0Kw							
	5.5Kw	126	110	260	246	183	173.3	φ 6
	7.5Kw	153	137	341	327	203.3	193.6	φ 7
	11Kw							
	15Kw	180	120	422.2	419.7	203.6	194	φ 9
	18.5Kw	191	120	471	450	241.4	231.6	φ 9
	22Kw							

380V Class

Structure	Power (Kw)	W (mm)	W1	H	H1	D	D1	Installation Hole
A Structure	0.75Kw	105	93.5	216	206	156.7	148.8	φ 4.5
	1.5Kw							
	2.2Kw							
	4.0Kw							
	5.5Kw	126	110	260	246	183	173.3	φ 6
	7.5Kw	153	137	341	327	203.3	193.6	φ 7
	11Kw							
	15Kw	180	120	422.2	419.7	203.6	194	φ 9
	18.5Kw	191	120	471	450	241.4	231.6	φ 9
	22Kw							
B Structure	30Kw	300	220	541	516	313.7	300	φ 11
	37Kw							
	45Kw	350	270	730	705	353.7	340	φ 11
	55Kw							
	75Kw	500	180	780	755	353.7	340	φ 11
	90Kw							
	110Kw	650	210	1060	1024	413.7	400	φ 16
	132Kw							
160Kw								
185Kw								
200Kw								

Structure	220Kw	750	230	1170	1128	413.7	400	φ 18
	250Kw							
B Structure	280Kw	850	275	1280	1236	463.7	450	φ 20
	315Kw							
	350Kw							
	400Kw							

5. Main Circuit Connection Functions

Terminal	Type	Function Description
R/L1 S/L2 T/L3	Main circuit power supply input	Input end of commercial power supply
U/T1 V/T2 W/T3	AC drive output terminal	AC driver output connected with 3-phase induction motor.
⊕2 PR	External braking resistor connection	=37KW with braking component which is connected to terminal ⊕2, PR. To improve the brake moment of force, an external braking resistance is needed.
⊕2/⊕ ⊖	Braking unit or Dc Input connection	1: Machinery=45KW without outside braking resistance component. To improve braking power, outside braking resistance and braking component is necessary (both are optional). 2: DC input terminal;
⊕2 ⊕1	DC reactor connection	Connect DC reactor to improve the power factor, reduce the DC bus AC pulse.
⊕	Grounding terminal	For safety and small noise, AC drive's ground terminal EG should be well grounded.

6. AC drive control terminal connections

Type	Terminal	Name	Function Description
Power supply	10V-GND	External+10V power supply	Provide +10V power supply for external unit, maximum output current: 10mA Generally, it provides power supply to external potentiometer with resistance range of 1kΩ.~5kΩ.
	24V-COM	External+24V power supply	Provide +24V power supply to external unit, generally, it provides power supply to S/Y terminals and external sensors. Maximum output current: 200mA
	PLC	Input terminal of external power supply	Connect to +24V by default when S1~S8 need to be driven by external signal, PLC needs to be connected to external power supply and be disconnected from +24V power supply terminal.
Analog input	AI1-GND	Analog input terminal 1	1. Input voltage range: DC 0V~10V 2. Impedance: 22kΩ
	AI2-GND	Analog input terminal 2	1. Input range: DC 0V~10V/4mA - 20mA, decided by selection of P5-00. 2. Impedance: 22kΩ (voltage input), 500Ω (current input)
	AI3-GND	Analog input terminal 3	

Type	Terminal	Name	Function Description
Digital input	S1-COM	Digital input 1	1. Optocoupler coupling isolation, compatible with dual polarity input 2. Impedance: 2.4kΩ 3. Voltage range for level input: 9V~30V 4. S8 can be used for high-speed pulse input. Maximum input frequency: 100kHz
	S2-COM	Digital input 2	
	S3-COM	Digital input 3	
	S4-COM	Digital input 4	
	S5-COM	Digital input 5	
	S6-COM	Digital input 6	
	S7-COM	Digital input 7	
	S8-COM	Digital input 8	
Analog output	A01-GND	Analog output terminal 1	Voltage or current output is decided by P5-32. Output voltage range: 0V~10V Output current range: 0mA~20mA
	A02-GND	Analog output terminal 2	
Digital output	Y3-YC	Digital output terminal 1	1. Optocoupler coupling isolation, dual polarity open collector output: 2. Output voltage range: 0~24 V 3. Output current range: 0~50 mA 4. Y4 is limited by F5-32 "HY function enable". As high-speed pulse output, the maximum frequency is 50 kHz. 5. Select whether YC terminal and COM terminal are electrically connected through SW1.
	Y4-YC	Digital output terminal 2	
	Y1A/Y1B/Y1C	Relay digital output 1	
	Y2A/Y2C	Relay digital output 2	
Communication	DA, DB	RS485 interface	1. Standard RS485 communication interface; 2. Select whether to connect 1200 termination resistor through SW2.

7. Operation and display

7.1 LED operation panel (Factory standard panel is LED.)

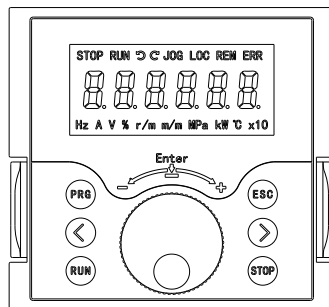

7.2 Description of LED operation panel indicators

Indicator	Description	Indicator	Description
STOP	motor STOP	RUN	motor RUN
↺	motor reverse rotation	↻	motor forward rotation
JOG	JOG state	LOC	control source as panel
REM	control mode set by the source of A03	ERR	AC drive has failure
Hz	monitoring interface is frequency	A	monitoring interface is current
V	monitoring interface is voltage	%	monitoring interface for percentage display
r/m	monitoring interface is motor speed	KW	monitoring interface is power
MPa	monitoring interface is MPa under monitor mode setting	°C	monitoring interface is temperature

7.3 Description of Keys on the LED operation panel

Key	Function
PRG	Programming Set parameters
</>	Move left and right function keys
RUN	RUN key Forward RUN (FRD)
STOP	STOP key
⊕	Number INCREASE/DECEREAASE and ENTER key
ESC	Exit and fault reset function

8. Faults and solutions

Display	Fault name	Possible causes	Solutions
Err01	Inverter unit protection	1: The output circuit is grounded or short circuited. 2: The power cable between the motor and the AC drive is too long. 3: The power module is overheated. 4: The internal connections become loose. 5: The main control board is faulty. 6: The drive board is faulty. 7: The inverter module is faulty.	1: Eliminate external faults. 2: Install a reactor or an output filter. 3: Check the air filter and the cooling fan. 4: Connect all cables properly. 5: Seek technical support. 6: Seek technical support. 7: Seek technical support.
Err02	Overcurrent during acceleration	1: The output circuit is grounded or short circuited. 2: Motor auto-tuning is not performed. 3: The acceleration time is too short.	1: Eliminate external faults. 2: Perform the motor auto-tuning. 3: Increase the acceleration time.

Err02	Overcurrent during acceleration	4: Manual torque boost or V/F curve is not appropriate. 5: The input voltage is too low. 6: The startup operation is performed on the rotating motor. 7: A sudden load is added during acceleration. 8: The AC drive model is of too small power class.	4: Adjust the manual torque boost or V/F curve. 5: Adjust the voltage to the normal range. 6: Select rotational speed tracking restart or start the motor after it stops. 7: Remove the added load. 8: Select an AC drive of higher power class.
Err03	Overcurrent during deceleration	1: The output circuit is grounded or short circuited. 2: Motor auto-tuning is not performed. 3: The deceleration time is too short. 4: The input voltage is too low. 5: A sudden load is added during deceleration. 6: The braking unit and braking resistor are not installed.	1: Eliminate external faults. 2: Perform the motor autotuning. 3: Increase the deceleration time. 4: Adjust the voltage to the normal range. 5: Remove the added load. 6: Install the braking unit and braking resistor.
Err04	Overcurrent at constant speed	1: The output circuit is grounded or short circuited. 2: Motor auto-tuning is not performed. 3: The input voltage is too low. 4: A sudden load is added during operation. 5: The AC drive model is of too small power class.	1: Eliminate external faults. 2: Perform the motor autotuning. 3: Adjust the voltage to the normal range. 4: Remove the added load. 5: Select an AC drive of higher power class.
Err05	Overvoltage during acceleration	1: The input voltage is too high. 2: An external force drives the motor during acceleration. 3: The acceleration time is too short. 4: The braking unit and braking resistor are not installed.	1: Adjust the voltage to normal range. 2: Remove the external force or install a braking resistor. 3: Increase the acceleration time. 4: Install the braking unit and braking resistor.
Err06	Overvoltage during deceleration	1: The input voltage is too high. 2: An external force drives the motor during deceleration. 3: The deceleration time is too short. 4: The braking unit and braking resistor are not installed.	1: Adjust the voltage to normal range. 2: Remove the external force or install a braking resistor. 3: Increase the deceleration time. 4: Install the braking unit and braking resistor.
Err07	Overvoltage at constant speed	1: The input voltage is too high. 2: An external force drives the motor during running.	1: Adjust the voltage to the normal range. 2: Remove the external force or install the braking resistor.
Err08	Control power supply fault	1: The input voltage is not within the allowable range.	1: Adjust the input voltage to the allowable range.
Err09	Undervoltage	1: Instantaneous power failure occurs on the input power supply. 2: The AC drive's input voltage is not within the allowable range. 3: The DC-Bus voltage is abnormal. 4: The rectifier bridge and buffer resistor are faulty.	1: Reset the fault. 2: Adjust the voltage to the normal range. 3: Contact technical support. 4: Contact technical support.

Err09	Undervoltage	5: The drive board is faulty. 6: The main control board is faulty.	5: Contact technical support. 6: Contact technical support.
Err10	AC drive overload	1: The load is too heavy or locked rotor occurs on the motor. 2: The AC drive model is of too small power class.	1: Reduce the load and check the motor and mechanical condition. 2: Select an AC drive of higher power class.
Err11	Motor overload	1: P9-23 is set improperly. 2: The load is too heavy or locked rotor occurs on the motor. 3: The AC drive model is of too small power class.	1: Set it correctly. 2: Reduce the load and check the motor and the mechanical condition. 3: Select an AC drive of higher power class.
Err12	Power input phase loss	1: The three-phase power input is abnormal. 2: The drive board is faulty. 3: The lightning board is faulty. 4: The main control board is faulty.	1: Eliminate external faults. 2: Seek technical support. 3: Seek technical support. 4: Seek technical support.
Err13	Power output phase loss	1: The cable connecting the AC drive and the motor is faulty. 2: The AC drive's three-phase outputs are unbalanced when the motor is running. 3: The drive board is faulty. 4: The module is faulty.	1: Eliminate external faults. 2: Check whether the motor three-phase winding is normal. 3: Seek technical support. 4: Seek technical support.
Err14	Module overheat	1: The ambient temperature is too high. 2: The air filter is blocked. 3: The fan is damaged. 4: The thermally sensitive resistor of the module is damaged. 5: The inverter module is damaged.	1: Lower the ambient temperature. 2: Clean the air filter. 3: Replace the damaged fan. 4: Replace the damaged thermally sensitive resistor. 5: Replace the inverter module.
Err15	External equipment fault	1: External fault signal is input via S.	1: Reset the operation.
Err16	Communication fault	1: The host computer is in abnormal state. 2: The communication cable is faulty. 3: The communication parameters in group PB are set improperly.	1: Check the cabling of host computer. 2: Check the communication cabling. 3: Set the communication parameters properly.
Err17	Contacting fault	1: The drive board and power supply are faulty. 2: The contactor is faulty.	1: Replace the faulty drive board or power supply board. 2: Replace the faulty contactor.
Err18	Current detection fault	1: The HALL device is faulty. 2: The drive board is faulty.	1: Replace the faulty HALL device. 2: Replace the faulty drive board.
Err19	Motor auto-tuning fault	1: The motor parameters are not set according to the nameplate. 2: The motor auto-tuning times out.	1: Set the motor parameters according to the nameplate properly. 2: Check the cable connecting the AC drive and the motor.
Err20	Encoder fault	1: The encoder type is incorrect. 2: The cable connection of the encoder is incorrect.	1: Set the encoder type correctly based on the actual situation. 2: Eliminate external faults.

Err20	Encoder fault	3: The encoder is damaged. 4: The PG card is faulty.	3: Replace the damaged encoder. 4: Replace the faulty PG card.
Err21	EEPROM readwrite fault	1: The EEPROM chip is damaged.	1: Replace the main control panel.
Err22	AC drive hardware fault	1: Overvoltage exists. 2: Overcurrent exists.	1: Handle based on over-voltage. 2: Handle based on over-current.
Err23	Short circuit to ground	1: The motor is short circuited to the ground.	1: Replace the cable or motor.
Err24	EEPORM Initialization fault	1: Abnormal user data.	1: Reinitialize data and set parameters.
Err26	Running time reached	1: Accumulative running time reaches setting.	1: Clear the record through the parameter initialization function.
Err27	User-defined fault 1	1: The user-defined fault 1 signal is input via S.	1: Reset the operation.
Err28	User-defined fault 2		
Err29	Power-on time reached	1: Accumulative power-on time reaches the setting.	1: Clear the record through the parameter initialization function.
Err30	Load becoming 0	1: The AC drive running current is lower than P9-38.	1: Check the load is disconnected or P9-38 and P9-39 is correct.
Err31	PID feedback lost during running	1: The PID feedback is lower than the setting of PA-27.	1: Check the PID feedback signal or set PA-27 to a proper value.
Err40	Pulse-by-pulse current limit fault	1: The load is too heavy or locked rotor occurs on the motor. 2: The AC drive model is of too small power class.	1: Reduce the load and check the motor and mechanical condition. 2: Select the AC drive of higher power class.
Err42	Too large speed deviation	1: The encoder parameters are set incorrectly. 2: The motor auto-tuning is not performed. 3: P9-42 and P9-43 are set incorrectly.	1: Set the encoder parameters properly. 2: Perform the motor autotuning. 3: Set P9-69 and P9-70 correctly based on the actual situation.
Err43	Motor over-speed	1: The encoder parameters are set incorrectly. 2: The motor auto-tuning is not performed. 3: P9-40 and P9-41 are set incorrectly	1: Set the encoder parameters properly. 2: Perform the motor auto-tuning. 3: Set P9-40 and P9-41 correctly based on the actual situation.
Err45	Motor overheat	1: The cabling of the temperature sensor becomes loose. 2: The motor temperature is too high.	1: Check the temperature sensor cabling and eliminate the cabling fault. 2: Lower the carrier frequency or adopt other heat radiation measures.
Err51	Pole position detection failed	1: The deviation between the motor parameters and the actual value is too large.	1: Reconfirm whether the motor parameters are correct, and focus on whether the rated current is set too small.

9. Function Code Table

P0 Standard Parameter group				
Function Code	Parameter Name	Setting Range	Default	Address
P0-00	AC drive rated G/P type selection	0: heavy load rating (G) constant torque application 1: light load rating (P) decreasing torque application	0	0000H
P0-01	Motor control mode	0: V/F control (direction LED is on) 1: Sensorless flux vector control (SVC) (direction LED slow blinking) 2: Closed-loop vector control (FVC) (direction LED fast blinking)	0	0001H
P0-02	Command source selection	0: Operation panel control (LOC LED on) 1: Terminal control (REM LED on) 2: RS485 Communication control (REM LED blinking) 3: Option card (REM LOC LED on) 4: Terminal switchover (REM LOC LED blinking)	0	0002H
P0-03	Main frequency source X selection	0: Operation panel digital setting frequency 1: AI1 2: AI2 3: AI3 4: Terminal pulse HS setting 5: RS485 communication setting 6: UP/DW setting 7: PID control setting 8: PLC mode operation setting 9: reserved A: reserved B: Option card C: Terminal switchover	0	0003H
P0-04	Main source X Gain	0.000~5.000	1.000	0004H
P0-05	Auxiliary frequency source Y selection	Same as P0-03	0	0005H
P0-06	Auxiliary source Y Gain	0.000~5.000	1.000	0006H
P0-07	Main and Auxiliary frequency source combination mode	0: Main frequency source X is valid 1: Auxiliary frequency source Y is valid 2: X+Y 3: X-Y 4: MAX (X , Y) 5: MIN (X , Y) 6: X*Y 7: Any non-zero value of the main frequency source X and auxiliary frequency source Y is valid, and the primary channel takes precedence.	0	0007H
P0-08	Digital setting of main source X frequency	0.00~Maximum output frequency	50.00Hz	0008H

P0-09	Digital setting of auxiliary source Y frequency	0.00~Maximum output frequency	50.00Hz	0009H
P0-10	Maximum output frequency	0.00~320.00Hz	50.00Hz	000AH
P0-11	Source of frequency upper limit selection	0: Set by P0-12 1: AI1 2: AI2 3: AI3 4: Terminal pulse setting 5: RS485 Communication setting	0	000BH
P0-12	Source of frequency upper limit digital setting	0~100.0%	100.0%	000CH
P0-13	Source of frequency lower limit digital setting	0~100.0%	0.0%	000DH
P0-14	Frequency lower limit run mode	0: Run at frequency lower limit 1: Stop 2: Run at zero speed	1	000EH
P0-15	Acceleration time 1	0.1~6500.0s	Model dependent	000FH
P0-16	Deceleration time 1	0.1~6500.0s	Model dependent	0010H
P0-17	Acceleration/Deceleration time unit	1: 0.1s 2: 0.01s	1	0011H
P0-18	Stopping method	0: Ramp to stop 1: Coast to stop	0	0012H
P0-19	Rotation direction selection	BIT0: 0: Forward direction operation 1: Reverse direction operation BIT1: 0: Reverse operation enable 1: Reverse operation disable	00	0013H
P0-20	Carrier frequency	1.0~15.0KHz	Model dependent	0014H
P0-21	Frequency reference resolution	1: 0.1Hz 2: 0.01Hz	2	0015H
P0-22	Reserved	-	-	0016H
P0-23	Parameter initialization	0: No operation 1: Data locked 2: Reset Error message 3~6: Undefined 7: Initialization setting—User data reset 10: Back up current user parameters 210: Restore user backup parameters	0~210	0017H

P1 Motor parameters				
Function Code	Parameter Name	Setting Range	Default	Address
P1-00	Motro Auto-tuning selection	0: No auto-tuning 1: Asynchronous motor stationary auto-tuning 2: Asynchronous motor (rotational)complete auto-tuning 3: Reserved	0	0100H
P1-01	Motor type	0: Common asynchronous motor 1: Variable frequency asynchronous motor	0	0101H
P1-02	Motor rated power	0.1kW~1000.0kW	Model dependent	0102H
P1-03	Motor rated voltage	1V~2000V	Model dependent	0103H
P1-04	Motor rated current	P1-11~655.35A (AC Drive<=55kW) P1-11~6553.5A (AC Drive>55kW)	Model dependent	0104H
P1-05	Motor rated frequency	0.01Hz~maximum frequency	Model dependent	0105H
P1-06	Motor rated rotational speed	1rpm~65535rpm	Model dependent	0106H
P1-07	Stator resistance (asynchronous motor)	0.001Ω ~ 65.535Ω (AC Drive<=55kW)	Model dependent	0107H
P1-08	Rotor resistance (asynchronous motor)	0.0001Ω ~ 6.5535Ω (AC Drive>55kW)	Model dependent	0108H
P1-09	Leakage inductive reactance (asynchronous motor)	0.01mH ~ 655.35mH (AC Drive<=55kW)	Model dependent	0109H
P1-10	Mutual inductive reactance (asynchronous motor)	0.001mH ~ 65.535mH (AC Drive>55kW)	Model dependent	010AH
P1-11	No-load current (asynchronous motor)	0.01A ~ P1-04 (AC Drive<=55kW) 0.1A ~ P1-04 (AC Drive>55kW)	Model dependent	010BH
P1-12 ~ P1-16	Reserved	-	-	010CH ~ 0110H
P1-23	Encoder type	BIT0: Encoder type 0: ABZ incremental encoder 1: UVW incremental encoder 2: Resolver 3: SIN/COS encoder 4: Wire-saving UVW encoder	000	0117H

P1-23	Encoder type	BIT1: A/B phase sequence of ABZ incremental encoder 0: Forward 1: Reverse BIT2: U, V, W phase sequence of UVW encoder 0: Forward 1: Reverse BIT3:UVW encoder 0: Forward 1: Reverse	000	0117H
P1-24	Encoder pulses per revolution	0~60000	1024	0118H
P1-25	Encoder installation angle	0.0~359.9°	0.0°	0119H
P1-26	UVW encoder angle offset	0.0~359.9°	0.0°	011AH
P1-27	Number of pole pairs of resolvers	1~100	1	011BH
P1-28	Encoder wire-break fault detection time	0.00~60.00s	2.00s	011CH
P2 Vector Control Parameters				
Function Code	Parameter Name	Setting Range	Default	Address
P2-00	Vector control mode	BIT0: SFVC optimization mode selection 1: optimization mode 1 2: Optimization mode 2 BIT1: Reserved BIT2: Reserved BIT3: Reserved	0001	0200H
P2-01	Speed loop proportional gain 1	1~100	30	0201H
P2-02	Speed loop integral time 1	0.01~10.00s	0.50s	0202H
P2-03	Switchover frequency 1	0.00~P2-06	5.00Hz	0203H
P2-04	Speed loop proportional gain 2	1~100	20	0204H
P2-05	Speed loop integral time 2	0.01~10.00s	1.00s	0205H
P2-06	Switchover frequency 2	P2-03~maximum frequency	10.00Hz	0206H
P2-07	Slip compensation factor	50~200%	100%	0207H
P2-08	Time constant of speed loop filter	0.001~1.000s	0.10s	0208H

P2-09	Vector control over-excitation gain	0~200	64	0209H
P2-10	Torque upper limit source in speed control mode	0: P2-11 function code setting 1: AI1 2: AI2 3: AI3 4: Pulse setting 5: Communication setting 6: MIN(AI1, AI2) 7: MAX(AI1, AI2)	0	020AH
P2-11	Digital setting of torque upper limit	0.0~200.0%	150.0%	020BH
P2-12	Reserved	-	-	020CH
P2-13	Reserved	-	-	020DH
P2-14	Current loop of M-axis Kp	0~60000	2000	020EH
P2-15	Current loop of M-axis Ki		1300	020FH
P2-16	Current loop of T-axis Kp		2000	0210H
P2-17	Current loop of T-axis Ki		1300	0211H
P2-18	Speed loop integral property		0: Invalid 1: Valid	0
P2-19	Over excitation mode selection	0: Disable 1: Reduce process enable 2: Constant speed and deceleration	1	0213H
P2-20	Over modulation enable selection	0~1	0	0214H
P2-21	Maximum output voltage coefficient	100~110%	105%	0215H
P2-22	Field weakening automatic adjustment gain	50~200%	100%	0216H
P2-23	Negative torque limit enable	0~1	0	0217H

P3 V/F Control Parameters				
Function Code	Parameter Name	Setting Range	Default	Address
P3-00	V/F curve selection	0: Linear V/F 1: Set P0-03 ~ P3-06 parameter to obtain any V/F relationship curve 2: Square V/F 3: 1.2-power V/F 4: 1.4-power V/F 6: 1.6-power V/F 8: 1.8-power V/F 9: Reserved 10: V/F complete separation 11: V/F half separation	0	0300H
P3-01	Multi-point V/F frequency1 (F1)	0.00~P3-03	1.00Hz	0302H
P3-02	Multi-point V/F voltage1 (V1)	0.0~P3-04	3.0%	0301H
P3-03	Multi-point V/F frequency2 (F2)	P3-01~P3-05	25.00Hz	0304H
P3-04	Multi-point V/F voltage2 (V2)	P3-02~P3-06	50.0%	0303H
P3-05	Multi-point V/F frequency3 (F3)	P3-03~maximum frequency	50.00Hz	0306H
P3-06	Multi-point V/F voltage3 (V3)	P3-04~100%	100%	0305H
P3-07	V/F Torque boost	0.0~30.0%	1.0%	0307H
P3-08	Cut-off frequency of torque boost	0.00~maximum frequency	50.00Hz	0308H
P3-09	Online torque compensation gain	80~150	100	0309H
P3-10	V/F slip compensation	0~200.0%	0.0%	030AH
P3-11	Slip compensation time constant	0.1~10.0s	0.5s	030BH
P3-12	Over excitation gain	0~2.00	0.64	030CH
P3-13	V/F oscillation suppression gain	0~1000	Model dependent	030DH
P3-14	Oscillation suppression mode selection	0~4	3	030DH
P3-15	Voltage source for V/F separation selection	0: Digital setting (P3-15) 1: AI1 2: AI2 3: AI3 4: Pulse setting (S5) 5: Multi-reference 6: Simple PLC 7: PID 8: Communication setting	0	030EH

P3-16	Voltage digital setting for V/F separation	0V~rated motor voltage	0V	030FH
P3-17	Voltage acceleration time of V/F separation	0.1~1000.0s	10.0s	0310H
P3-18	Voltage deceleration time of V/F separation	0.1~1000.0s	10.0s	0311H
P3-19	V/F separation shutdown mode	0: Frequency/voltage independent reduction to 0. 1: After the voltage is reduced to 0, the frequency is reduced to 0 again.	0	0312H
P3-20	Overcurrent stall action current	50~200%	150%	0312H
P3-21	Overcurrent stall suppression enable	0: Invalid 1: Valid	1	0312H
P3-22	Overcurrent stall suppression gain	0~100	20	0312H
P3-23	Stall current compensation factor	50~200%	50%	0312H
P3-24	Overvoltage stall action voltage	200.0V~2000.0V 220V:380V 690V:1250V 380V:760V 1140V:1900V 480V:850V	Model dependent	0312H
P3-25	Overvoltage stall enable	0: Invalid 1: Valid	1	0312H
P3-26	Overvoltage stall frequency gain	0~100	30	0312H
P3-27	Overvoltage stall voltage gain	0~100	30	0312H
P3-28	Overvoltage stall maximum frequency	0~50Hz	5Hz	0312H
P3-29	Automatic up-scaling enable	0~1	0	0312H
P3-30	Minimum electric torque current	0A~64A	32A	0312H
P3-31	Minimum generation torque current	10~100%	20%	0312H
P3-32	Automatic up-scaling KP	0~100	30	0312H
P3-33	Automatic up-scaling KI	0~100	30	0312H

P4 Input Terminals function				
Function Code	Parameter Name	Setting Range	Default	Address
P4-00	S1 terminal function	0: No function 2: Reverse RUN (REV) 4: Forward JOG (FJOG) 6: Coast to stop 8: Fault reset (RESET) 9: External fault input 10: Terminal UP 11: Terminal YWN	1	0400H
P4-01	S2 terminal function	1: Forward RUN (FWD) 3: Three-Wire control 5: Reverse JOG (RJOG) 7: Emergency stop 12: UP and YWN setting clear 13: Speed control/Torque control switchover 14: Speed search start enable 15: Reserved	2	0401H
P4-02	S3 terminal function	16: Multi-reference terminal 1 17: Multi-reference terminal 2 18: Multi-reference terminal 3 19: Multi-reference terminal 4 20: Terminal 1 for acceleration/deceleration time selection 21: Terminal 2 for acceleration/deceleration time selection 22: Acceleration/Deceleration prohibited	4	0402H
P4-03	S4 terminal function	23: PID control cancel 24: PID control pause 25: PID integral pause 26: PID characteristic switching 27: PID parameter switchover	5	0403H
P4-04	S5 terminal function	28: PID target value switchover terminal1 29: PID target value switchover terminal2 30: PID target value switchover terminal3 31: PID feedback value switchover terminal1 32: PID feedback value switchover terminal2 33: PID feedback value switchover terminal3 34: PLC pause 35: PLC status reset 36: Swing enable 37: Swing pause 38: Swing reset	6	0404H
P4-05	S6 terminal function	39: Frequency source switchover terminal1 40: Frequency source switchover terminal2 41: Frequency source switchover terminal3 42: Frequency source switchover terminal4	8	0405H
P4-06	S7 terminal function	43: Command source switchover terminal 1 44: Command source switchover terminal 2 45: Counter input terminal 46: Counter reset terminal 47: Counter clock input terminal 48: Counter reset	10	0406H
P4-07	S8 terminal function	49: DC braking command 50: Terminal pre-excitation 51: User-defined fault1 52: User-defined fault2 53: Pump 1 invalid 54: Pump 2 invalid 55: Pump 3 invalid 56: Pump 4 invalid	11	0407H

P4-08	Characteristic selection of terminal S1-S4	BIT0: S1 terminal 0: Effective closing 1: Effective opening BIT1: S2 terminal 0: Effective closing 1: Effective opening BIT2: S3 terminal 0: Effective closing 1: Effective opening BIT3: S4 terminal 0: Effective closing 1: Effective opening	0000	0408H
P4-09	Filter time of terminal S1-S4	0.000~60.00s	0.10s	0409H
P4-10	Characteristic selection of terminal S5-S8	BIT0: S5 terminal 0: Effective closing 1: Effective opening BIT1: S6 terminal 0: Effective closing 1: Effective opening BIT2: S7 terminal 0: Effective closing 1: Effective opening BIT3: S8 terminal 0: Effective closing 1: Effective opening	0000	040AH
P4-11	Filter time of terminal S5-S8	0.000~60.00s	0.1s	040BH
P4-12	Terminal command mode	0: Two-line mode 1 Terminal set as 1 is forward running, terminal set as 2 is reverse running 1: Two-line mode 2 Terminal set as 1 is start running, terminal set as 2 is switch forward and reverse running 2: Three-line mode 1 Terminal set as 1 is forward running, terminal set as 2 is reverse running, terminal set as 3 is stop running 3: Three-line mode 2 Terminal set to 1 is start running, terminal set as 2 is switch forward and reverse, terminal set as 3 is Stop running	0	040CH
P4-13	Terminal action mode selection	BIT0: Terminal of coast to stop recovery mode 0: Restore the original instruction after invalidation 1: Do not restore the original instruction after invalidation BIT1: Terminal of emergency stop recovery mode 0: Restore the original instruction after invalidation 1: Do not restore the original instruction after invalidation BIT2: Select the terminal operation mode after fault reset 0: The terminal operation command is valid immediately 1: The terminal operation command is valid only after it is canceled	111	040DH

P4-14	Reserved	-	-	040EH
P4-15	Reserved	-	-	040FH
P4-16	Terminal protection function selection	BIT0: 0: Invalid terminal operation command when power on 1: Valid terminal operation command when power on BIT1: When the run command setting channel terminal switching, selection of run command is valid 0: The running command is valid after stopping during switching 1: The run command is valid immediately when switching	00	0410H
P4-17	UP/DW frequency value	0.0~1.000	0.01	0411H
P4-18	UP /DW frequency adjustment selection	0: Retentive at power failure 1: Non-retentive at power failure 2: Valid operation, stop and reset	0	0412H
P4-19	Speed of UP/DW frequency increase and decrease	0.1~100.0%/s	2.0%/s	0413H
P4-20	Y1 terminal function	0: No output 1: Forward running 2: Reverse running 3: Fault output1 (no output at auto-reset period) 4: Fault output2 (output at auto-reset period)	1	0414H
P4-21	Y2 terminal function	5: Ready for RUN 6: Frequency reached 7: Frequency-level detection FDT1 output 8: Frequency-level detection FDT2 output	2	0415H
P4-22	Y3 terminal function	9: Frequency upper limit reached 10: Frequency lower limit reached 11: Current 1 reached 12: Current 2 reached	3	0416H
P4-23	Y4 terminal function	13: Zero current output 14: Output current out of limit 15: Torque limited 16: OL1 motor overload pre-warning 17: OL2 AC drive overload pre-warning	6	0417H
P4-24	Y5 terminal function-Extension	18: Zero-speed running (no output at stop) 19: Acceleration running 20: Deceleration running 21: Dc braking 22: PLC step completed 23: PLC cycle completed 24: Reserved	0	0418H
P4-25	Y6 terminal function-Extension	25: Accumulative running time reached 26: Timing reached 27: Maximum count value reached 28: Set count value reached 29: All input out of limit	0	0419H

P4-26	Y7 terminal function-Extension	30: Module temperature Reached 31: Fan running 32: Data output 1 from transfer(Y function) 33: Data output 2 from transfer(Y function) 34: Data output 3 from transfer(Y function) 35: Data output 4 from transfer(Y function)	0	041AH
P4-27	Y8 terminal function-Extension	36: Pump 1 start-up 37: Pump 2 start-up 38: Pump 3 start-up 39: Pump 4 start-up	0	041BH
P5 Analog terminal parameters				
Function Code	Parameter Name	Setting Range	Default	Address
P5-00	AI123 input signal selection	BIT0: AI2 signal selection 0: 0~10V 1: 0~20.00mA BIT1: AI3 signal selection 0: 0~10V 1: 0~20.00mA BIT2: AI3 signal selection 0: 0~10V 1: 0~20.00mA BIT3: Reserved	0010	0500H
P5-01	AI1 input voltage minimum value	0.00~10.00V	0.00V	0501H
P5-02	AI1 input voltage lower limit corresponding setting	0.00~100.00%	0.00%	0502H
P5-03	AI1 input voltage maximum value	0.00~10.00V	10.00V	0503H
P5-04	AI1 input voltage upper limit corresponding setting	0.00~100.00%	100.00%	0504H
P5-05	AI1 filter time	0.00~10.00s	0.10s	0505H
P5-06	AI2 input voltage minimum value	0.00~10.00V	0.00V	0506H
P5-07	AI2 input voltage lower limit corresponding setting	0.00~100.00%	0.00%	0507H
P5-08	AI2 input voltage maximum value	0.00~10.00V	10.00V	0508H
P5-09	AI2 input voltage upper limit corresponding setting	0.00~100.00%	100.00%	0509H
P5-10	AI2 filter time	0.00~10.00s	0.10s	050AH
P5-11	AI3 input voltage minimum value	0.00~10.00V	0.00V	050BH

P5-12	AI3 input voltage lower limit corresponding setting	0.00~100.00%	0.00%	050CH	
P5-13	AI3 input voltage maximum value	0.00~10.00V	10.00V	050DH	
P5-14	AI3 input voltage upper limit corresponding setting	0.00~100.00%	100.00%	050EH	
P5-15	AI3 filter time	0.00~10.00s	0.10s	050FH	
P5-16	HS minimum input frequency	0.00~50.00KHz	0.00KHz	0510H	
P5-17	Corresponding setting of HS minimum input frequency	0.00~100.00%	0.00%	0511H	
P5-18	HS maximum input frequency	0.00~50.00KHz	50.00KHz	0512H	
P5-19	Corresponding setting of HS maximum input frequency	0.00~100.00%	100.00%	0513H	
P5-20	HS filter time	0.00~10.00s	0.10s	0514H	
P5-21 ~ P5-28	Reserved	-	-	0515H ~ 051CH	
P5-29	A01 output selection	0: Set frequency 2: Output current 4: Mechanical speed 6: Output torque 8: PID feedback 10: Bus voltage 12: AI1 input value 14: AI3 input value 15: PUL input value 16: Module temperature 17: Internal temperature 18: Excitation quantity 19: RS485 communication settings	1: Output frequency 3: Output voltage 5: Set torque 7: PID setting 9: Output power 11: Input voltage 13: AI2 input value	0	051DH
P5-30	A02 output selection			1	051EH
P5-31	HY output selection			2	051FH
P5-32	Analog output signal selection	BIT0: A01 signal selection 0: 0~10V 1: 4.00~20.00mA 2: 0.00~20.00mA BIT1: A02 signal selection 0: 0~10V 1: 4.00~20.00mA 2: 0.00~20.00mA BIT2: HY function enable 0: Ordinary switching value Y4 function 1: HY high speed pulse output function BIT3: Reserved		000	0520H

P5-33	A01 output gain	25.0~200.0%	100.0%	0521H
P5-34	A01 output offset coefficient	-10.0~10.0%	0.0%	0522H
P5-35	A02 output gain	25.0~200.0%	100.0%	0523H
P5-36	A02 output offset coefficient	-10.0~10.0%	0.0%	0524H
P5-37	HY pulse output lower limit	0.00~50.00KHz	0.20KHz	0525H
P5-38	HY pulse output upper limit	0.00~50.00KHz	50.00KHz	0526H
P6 Start/Stop Control parameters				
Function Code	Parameter Name	Setting Range	Default	Address
P6-00	Start mode	BIT0: Start mode 0: Direct start 1: First braking and then start by startup frequency 2: Rotational speed tracking RESTART	0	0600H
P6-01	Minimum output frequency	0.00~P6-04	0.50Hz	0601H
P6-02	Startup pre-excited current	0~100%	30%	0602H
P6-03	Startup pre-excited time	0.00~60.00s	Model dependent	0603H
P6-04	Startup frequency	0.00~60.00Hz	0.50Hz	0604H
P6-05	Startup frequency holding time	0.00~50.00s	0.0s	0605H
P6-06	Startup DC braking current	0~150%	0%	0606H
P6-07	Startup DC braking time	0.0~300.0s	0.0s	0607H
P6-08	Initial frequency of stop DC braking	0.00~50.00Hz	0.00Hz	0608H
P6-09	Stop DC braking current	0~150%	0%	0609H
P6-10	Waiting time of stop DC braking	0.00~60.00s	0.0s	060AH
P6-11	Stop DC braking holding time	0.00~600.0s	0.0s	060BH
P6-12	Zero speed holding current	0~150%	0%	060CH
P6-13	Acceleration mode selection	BIT0: Acceleration/Deceleration time frequency base 0: Base:50.00Hz 1:Maximum frequency BIT1: S-curve selection 0: Straight line 1: Curve	00	060DH

P6-14	Start of S-curve acceleration time	0.01~20.00s	0.50	060EH	
P6-15	End of S-curve acceleration time		0.50	060FH	
P6-16	Start of S-curve deceleration time		0.50	0610H	
P6-17	End of S-curve deceleration time		0.50	0611H	
P6-18	Rotational speed tracking mode	0: From frequency at stop 2: From maximum frequency	1: From zero speed	0	0612H
P6-19	Waiting time of rotational speed tracking	0.0~600.0s	1.0s	0613H	
P6-20	Tracking speed of rotational speed	0~100	20	0614H	
P6-21	Torque tracking closed loop current KP	0~1000	50	0615H	
P6-22	Torque tracking closed loop current KI	0~1000	50	0616H	
P6-23	Torque tracking current	30%~200%	100%	0617H	
P6-24	Torque tracking current lower limit	10~100%	30%	0618H	
P6-25	Torque tracking rise time	0.5~30s	1.1	0619H	
P6-26	Torque tracking demagnetization time	0.00~5.00s	1.00s	061AH	
P7 System configuration parameters					
Function Code	Parameter Name	Setting Range	Default	Address	
P7-00	Parameter and key lock selection	BIT0: 0: Not locked 1: Function parameter locking 2: Function parameters and key locking (except RUN/STOP/JOG) 3: Function parameters and keys are fully locked	0	0700H	
P7-01	User password	0~65535	0	0701H	
P7-02	STOP key function	BIT0: 0: Invalid for terminal command 1: Valid for terminal command BIT1: 0: Invalid for communication command 1: Valid for communication command BIT2: 0: Invalid for expansion card command 1: Valid for expansion card command	000	0702H	

P7-03	MF.K Key function selection	BIT0: Panel digital potentiometer setting selection 0: Invalid 2: Auxiliary frequency 4: V/F separated voltage 6: PID feedback BIT1: 0: Directly valid after the knob is modified 1: Press the Enter key to be valid after the knob is modified	1: Main frequency 3: Upper frequency 5: PID setting 7: Torque setting	01	0703H
P7-04	Copy of function parameters	0: No operation 1: Proofread data, parameter copy 2: Write keyboard data to AC drive		0	0704H
P7-05	Display speed factor	0.001~50.000		1.000	0705H
P7-06	First line run display	BIT0: The first group displays BIT1: The second group displays BIT2: The third group displays BIT3: The fourth group displays		6321	0706H
P7-07	First line stop display	0: Given frequency 2: Output current 4: Input voltage 6: Bus voltage 8: Given torque A: AI1 input value E: PID setting	1: Output frequency 3: Output voltage 5: Mechanical speed 7: Output power 9: Output torque B: AI2 input value D: Power factor F: Counter value	Ca40	0707H
P7-08	Second line run display			0792	0708H
P7-09	Second line stop display			OCA4	0709H
P7-10	Multi-function expansion card selection	0~8		0	070AH
P7-11	operation panel display item selection	BIT0: LCD operation panel display language Set LCD operation panel display language, only valid when using LCD operation panel. 0: Chinese 1: English BIT1: Output frequency display selection 0: Target frequency displays the target frequency of the current control motor. 1: Synchronous frequency displays the output frequency after converting operation. BIT2: Reserved BIT3: LCD contrast adjustment 0-f: The larger the contrast value		8001	070BH
P7-12	Accumulated power-on days	0~65535		Read-only	070CH
P7-13	Accumulated power-on hours	0.0~6553.5		Read-only	070DH
P7-14	Accumulated running days	0~65535		Read-only	070EH
P7-15	Accumulated running hours	0.0~6553.5		Read-only	070FH

P7-16	Accumulative power consumption (10000 kWh)	0~65535 million kWh	Read-only	0710H
P7-17	Accumulative power consumption	0~65535kWh	Read-only	0711H
P7-18	AC drive status before power off	BIT0: 0: Stop 1: Run BIT1: 0: Forward RUN 1: Reverse RUN BIT2: Reserved BIT3: Reserved	0000	0712H
P8 Auxiliary Functions				
Function Code	Parameter Name	Setting Range	Default	Address
P8-00	Forward JOG running frequency (FJOG)	0.00Hz to maximum frequency	5.00Hz	0800H
P8-01	Reverse JOG running frequency (RJOG)	0.00Hz to maximum frequency	5.00Hz	0801H
P8-02	JOG acceleration time	0.1~6500.0s	10.0s	0802H
P8-03	JOG deceleration time		10.0s	0803H
P8-04	Acceleration time 2		10.0s	0804H
P8-05	Deceleration time 2		10.0s	0805H
P8-06	Acceleration time 3		10.0s	0806H
P8-07	Deceleration time 3		10.0s	0807H
P8-08	Acceleration time 4		10.0s	0808H
P8-09	Deceleration time 4		10.0s	0809H
P8-10	Emergency stop deceleration time		10.0s	080AH
P8-11	Forward/Reverse rotation dead-zone time		0.0~150.00s	0.00s
P8-12	Jump frequency 1	0.00Hz to maximum frequency	0.00Hz	080CH
P8-13	Jump frequency 2		0.00Hz	080DH
P8-14	Jump frequency amplitude		0.00Hz	080DH
P8-15	Frequency detection value (FDT1)		30.00Hz	080FH
P8-16	Detection range of FDT1		0.00Hz	0810H

P8-17	Frequency detection value (FDT2)	0.00Hz to maximum frequency	50.00Hz	0811H
P8-18	Detection range of FDT2		0.00Hz	0812H
P8-19	Detection range of frequency consistent		3.00Hz	0813H
P8-20	current reaching 1 detection value	0~200.0%	100.0%	0814H
P8-21	current reaching 1 detection range	0~100.0%	5.0%	0815H
P8-22	current reaching 2 detection value	0~200.0%	150.0%	0816H
P8-23	Current reaching 2 detection range	0~100.0%	5.0%	0817H
P8-24	Zero current detection level	0~200.0%	5.0%	0818H
P8-25	Zero current detection delay time	0.0%~650.0%	0.20s	0819H
P8-26	Output overcurrent threshold	0.0%~200.0%	100%	081AH
P8-27	Output overcurrent detection delay	0.0%~650.0%	0.20s	081BH
P8-28	Timing operation function	BIT0: Timing function selection 0: Invalid 1: Valid BIT1: Timing operation time selection 0: P8-29 setting 1: AI1 2: AI2 3: AI3 Analog input range 100% corresponds to P8-28 BIT2: Reserved BIT3: Reserved	00	081CH
P8-29	Timing duration setting	0.0~6500.0Min	0.0Min	081DH
P8-30	Timer time unit	0: Second 1: Minute 2: Hour	0	081EH
P8-31	Timer set value	0~65000	0	081FH
P8-32	Counter Max	0~65000	1000	0820H
P8-33	Counter set value	0~65000	500	0821H
P8-34	AI1 voltage protection value lower limit	0.0~P8-35	3.10V	0822H
P8-35	AI1 voltage protection value upper limit	P8-34~10.00V	6.80V	0823H
P8-36	Module temperature reached	0~100°C	75.0°C	0824H

P9 Fault and protection parameters				
Function Code	Parameter Name	Setting Range	Default	Address
P9-00	Protection function selection 1	BIT0: Motor overload protection selection 0: Invalid 1: Valid BIT1: Ground fault during power-on 0: Invalid 1: Valid BIT2: Input phase loss protection selection 0: Invalid 1: Valid BIT3: Output phase loss protection selection 0: Invalid 1: Valid	1111	0900H
P9-01	Protection function selection 2	BIT0: Output load loss protection selection 0: Invalid 1: Ramp to stop BIT1: Instantaneous power failure action selection 0: Invalid 1: Valid BIT2: Continue operation frequency selection in case of failure 0: Operate at current operation frequency 1: Operate at set frequency 2: Operate at the upper limit frequency 3: Operate at the lower limit frequency 4: Operation at abnormal standby frequency BIT3: Reserved	000	0901H
P9-02	Fault auto reset times	0: OFF Automatic reset function is turned off, only manual reset is allowed. 1-20: ON This function is on, 1-20 is the number of times of self recovery after failure (defined as the maximum number of times of auto reset after each failure)	0	0902H
P9-03	Time interval of fault auto reset	0.1~100.0s	1.0s	0903H
P9-04	1st fault type	1 -- ERROR_INVERTER_UNIT 2 -- ERROR_OC_DURING_ACC 3 -- ERROR_OC_DURING_DEC 4 -- ERROR_OC_AT_CONST_SPEED 5 -- ERROR_OV_DURING_ACC 6 -- ERROR_OV_DURING_DEC 7 -- ERROR_OV_AT_CONST_SPEED 8 -- ERROR_CONTROL_POWER_SUPPLY 9 -- ERROR_UV 10 -- ERROR_OL_AC_DRIVE 11 -- ERROR_OL_MOTOR 12 -- ERROR_LOSE_PHASE_INPUT 13 -- ERROR_LOSE_PHASE_OUTPUT 14 -- ERROR_OH_MODULE	Read-only	0904H

P9-05	2nd fault type	15 -- ERROR_EXTERNAL_EQUIPMENT 16 -- ERROR_COMMUNICATE 17 -- ERROR_CONTACTOR 18 -- ERROR_CURRENT_DETECTION 19 -- ERROR_AUTO-TUNING 20 -- ERROR_ENCODER 21 -- ERROR_EEPROM_READWRITE 22 -- ERROR_HARDWARE_AC_DRIVE 23 -- ERROR_MOTOR_SHORT_TO_GND 24 -- ERROR_ERRPROM_INITIALIZE 26 -- ERROR_RUNNING_TIME_REACHED 27 -- ERROR_USER-DEFINED_1 28 -- ERROR_USER-DEFINED_2 29 -- ERROR_POWER-ON_TIME_REACHED 30 -- ERROR_LOAD_0 31 -- ERROR_PID_FDB_LOSE 40 -- ERROR_PBP_CURRENT_LIMIT 41 -- ERROR_SWITCH_MOTOR_WHEN_RUN 42 -- ERROR_TOO_LARGE_SPEED_DEVIATION 43 -- ERROR_MOTOR_OS 45 -- ERROR_MOTOR_OH 51 -- ERROR_POLE_POSITION_DETECTION 52 -- ERROR_ZERO_POSITION_IDENTIFICATION 53 -- ERROR_FEEDBACK_UVW_SIGNAL	Read-only	0905H
P9-06	3rd fault type		Read-only	0906H
P9-07	Failure operation frequency	0.00~655.35Hz	Read-only	0907H
P9-08	Failure output current	0.1~2000.0A	Read-only	0908H
P9-09	Failure DC-bus voltage	0~3000V	Read-only	0909H
P9-10	Failure AC drive status	BIT0: Direction of operation 0: FWD 1: REV BIT1: Running state 0: STOP 1: CONST 2: ACC 3: DEC BIT2: RESERVED BIT3: RESERVED	Read-only	090AH
P9-11	Failure S terminal status	See input terminal status diagram	Read-only	090BH
P9-12	Failure Y terminal status	See input terminal status diagram	Read-only	090CH
P9-13	Failure power on time	0~65535	Read-only	090DH
P9-14	Failure running time	0~65535	Read-only	090EH
P9-15	Frequency upon 2nd fault	0.00~655.35Hz	Read-only	090FH
P9-16	Current upon 2nd fault	0.1~2000.0A	Read-only	0910H
P9-17	Output voltage upon 2nd fault	0~3000V	Read-only	0911H

P9-18	AC drive status upon 2nd fault	Same as P9-10	Read-only	0912H
P9-19	S terminal status upon 2nd fault	Same as P9-11	Read-only	0913H
P9-20	Y terminal status upon 2nd fault	Same as P9-12	Read-only	0914H
P9-21	Power-on time upon 2nd fault	Same as P9-13	Read-only	0915H
P9-22	Running time upon 2nd fault	Same as P9-14	Read-only	0916H
P9-23	Frequency upon 3rd fault	0.00~655.35Hz	Read-only	0917H
P9-24	Current upon 3rd fault	0.1~2000.0A	Read-only	0918H
P9-25	Output voltage upon 3rd fault	0~3000V	Read-only	0919H
P9-26	AC drive status upon 3rd fault	Same as P9-10	Read-only	091AH
P9-27	S terminal status upon 3rd fault	Same as P9-11	Read-only	091BH
P9-28	Y terminal status upon 3rd fault	Same as P9-12	Read-only	091CH
P9-29	Power-on time upon 3rd fault	Same as P9-13	Read-only	091DH
P9-30	Running time upon 3rd fault	Same as P9-14	Read-only	091EH
P9-31	Backup frequency upon abnormality	0.0~100.0%	100.0%	091FH
P9-32	Motor overload protection gain	0.20~10.00	1.00	0920H
P9-33	Motor overload warning coefficient	50~100%	90%	0921H
P9-34	Recognize voltage at instantaneous stop action	0~100%	80%	0922H
P9-35	Recognize voltage at instantaneous stop action	0~100%	80%	0923H
P9-36	Recognize time at instantaneous rise action	0.00~100.00s	0.50s	0924H
P9-37	Instantaneous stop deceleration gain	0~200%	100%	0925H
P9-38	Detection level of load becoming 0	0.0~100.0%	10.0%	0926H
P9-39	Detection time of load becoming 0	0.0~60.0s	1.0s	0927H
P9-40	Over-speed detection value	0.0~50.0%(Maximum frequency)	20.0%	0928H

P9-41	Over-speed detection time	0.0~60.0s	1.0s	0929H
P9-42	Detection value of too large speed deviation	0.0~50.0%(Maximum frequency)	20.0%	092AH
P9-43	Detection time of too large speed deviation	0.0~60.0s	5.0s	092BH
P9-44	Overvoltage stall gain	0~100	0%	092CH
P9-45	Overvoltage stall protective voltage	120~150%	130%	092DH
P9-46	Overcurrent stall gain	0~100	20	092EH
P9-47	Overcurrent stall protective current	100~200%	150%	092FH
P9-48	Input phase loss protection level	1~200%	20%	0930H
P9-49	Input phase loss protection delay	2~250.0s	8s	0931H
P9-50	Protection action selection 1	BIT0: Motor overload (Err11) action select 0: Immediately-stop, fault alarm 1: Emergency stop, fault alarm 2: Only warning, AC drive continues to operate BIT1: Input phase loss (Err12) action select Same as BIT0 BIT2: Output phase loss (Err13) action select Same as BIT0 BIT3: External fault (Err15) action select Same as BIT0	0000	0932H
P9-51	Protection action selection 2	BIT0: Abnormal communication (Err16) action selection Same as P9-50 BIT0 BIT1: Encoder failure (Err20) action select 0: Immediately-stop, fault alarm 1: Emergency stop, fault alarm 2: Switch to VF, continue operation BIT2: Function code reading and writing abnormal (Err21) action selection 0: Immediately-stop, fault alarm 1: Emergency stop, fault report BIT3: Motor overheating (Err25) action select Same as BIT0	0000	0933H
P9-52	Protection action selection 3	BIT0: User defined fault 1 (Err27) action selection Same as P9-50 BIT0 BIT1: User defined fault 2 (Err28) action selection Same as BIT0	0000	0934H

P9-52	Protection action selection 3	BIT2: Power on time arrival (Err29) action selection Same as BIT1 BIT3: Load loss (Err30) action selection 0: Immediately-stop, fault alarm 1: Emergency stop, fault alarm 2: Directly jump to 7% of the rated frequency of the motor to continue operation, and automatically return to the set frequency operation during no-load operation	0000	0934H
P9-53	Protection action selection 4	BIT0: Loss of PID feedback during operation (Err31) action selection Same as PB-01 BIT0 BIT1: Excessive speed deviation (Err42) action selection Same as BIT0 BIT2: Motor over speed (Err43) action selection Same as BIT0 BIT3: Initial position error (Err51) action selection Same as BIT0	0000	0935H
P9-54	Protection action selection 5	BIT0: Speed feedback error (Err52) action selection Same as PB-01 BIT0 BIT1: Reserved BIT2: Reserved BIT3: Reserved	0	0936H
P9-58	Instantaneous stop and non-stop gain KP	0~100	40	0937H
P9-59	Instantaneous stop and non-stop integral coefficient PI	0~100	30	0938H
PA Process PID control parameters				
Function Code	Parameter Name	Setting Range	Default	Address
PA-00	PID setting source	0: PID setting source 1: AI1 2: AI2 3: AI3 4: Terminal pulse setting(PUL) 5: Communication setting 6: PLC setting 7: UP/DW control 8: Terminal selection	0	0A00H
PA-01	PID digital setting	0.00~PA-05	0.5Mpa	0A01H
PA-02	PID control feedback signal source	0: PID setting source 1: AI1 2: AI2 3: AI3 4: Terminal pulse feedback	2	0A02H

PA-02	PID control feedback signal source	K 5: Communication feedback 6: AI1 + AI2 7: MAX(AI1 , AI2) 8: MIN(AI1 , AI2) 9: Option card	2	0A02H
PA-03	PID digital feedback	0.00~PA-05	1.00Mpa	0A03H
PA-04	Feedback signal gain	0.00~10.000	1.000	0A04H
PA-05	Feedback signal range	0~655.35	1.00	0A05H
PA-06	PID control selection 1	BIT0: Feedback feature selection 0: Positive characteristic when the feedback signal of PID is less than the given value, the output frequency of AC drive will rise. 1: Negative characteristic when the feedback signal of PID is less than the given value, the output frequency of AC drive will decrease. BIT1: PID parameter switching condition 0: No switching 1: Switching through S terminal 2: Switch automatically according to deviation BIT2: Integral separation 0: Invalid 1: Valid When the multi-functional digital terminal integration pause is effective, the PID integration stops operation, and at this time, the PID only has the proportional and differential functions. BIT3: Stop integration after output to limit value 0: Continue integral 1: Stop integral After the PID operation output reaches the maximum or minimum value, you can choose whether to stop the integration. If stop integral is selected, then PID integral stops calculation at this time, which may help to reduce PID overshoot.	0000	0A06H
PA-07	PID control selection 2	BIT0: PID shutdown operation 0: Shutdown without calculation 1: Operation when shutdown BIT1: Constant pressure water supply sleep function 0: Invalid 1: Valid BIT2: Reserved BIT3: Reserved	00	0A07H
PA-08	Proportional gain Kpl	0.00~100.00	20.00	0A08H
PA-09	Integral time Tl	0.00~10.00s	2.00s	0A09H

PA-10	Differential time Td1	0.000~10.000s	0.000s	0A0AH
PA-11	Cut-off frequency of PID reverse rotation	0.00~maximum frequency	2.00Hz	0A0BH
PA-12	PID deviation limit	0.0~100.0%	0.0%	0A0CH
PA-13	PID differential limit	0.0~100.00%	0.10%	0A0DH
PA-14	PID setting change time	0.00~10.00s	0.00s	0A0EH
PA-15	PID feedback filter time	0.00~650.00s	0.00s	0A0FH
PA-16	PID output filter time	0.00~60.00s	0.00s	0A10H
PA-17	Reserved	-	-	0A11H
PA-18	Proportional gain Kp2	0.00~100.00	20.00	0A12H
PA-19	Integral time Ti2	0.00~10.00s	2.00s	0A13H
PA-20	Differential time Td2	0.00~10.000s	0.000s	0A14H
PA-21	PID parameter switchover deviation 1	0.0~PA-22	20.0%	0A15H
PA-22	PID parameter switchover deviation 2	PA-21~100.0%	80.0%	0A16H
PA-23	PID initial value	0.0~100.0%	0.0%	0A17H
PA-24	PID initial value running time	0.0~6500.0s	0.0s	0A18H
PA-25	Maximum deviation between two PID outputs in forward direction	0.00~100.00%	1.00%	0A19H
PA-26	Maximum deviation between two PID outputs in reverse direction	0.00~100.00%	1.00%	0A1AH
PA-27	Detection value of disconnection alarm	0.0~100.0%	0.0%	0A1BH
PA-28	Feedback disconnection detection time	0.0~120.0s	1.0s	0A1CH
PA-29	Dormant judgment benchmark	0.1~100.0%	95.0%	0A1DH

PA-30	Dormant base duration	0.1~6500.0S	30.0s	0A1EH
PA-31	Enter dormant deceleration time	0.1~6500.0S	60.0s	0A1FH
PA-32	Sleep low holding frequency	0.00~20.00Hz	10.00Hz	0A20H
PA-33	Low frequency operation time	0.0~6500.0S	10.0s	0A21H
PA-34	Wake-up base	0.0~100.0%	50.0%	0A23H
PA-35	Wake-up base duration	0.0~6500.0S	30.0s	0A24H
PB Communication control function parameters				
Function Code	Parameter Name	Setting Range	Default	Address
PB-00	Master-slave selection	Master-slave selection 0:Slave 1:Master	0	0B00H
PB-01	Address	1~247	1	0B01H
PB-02	Baud rate selection	0: 1200bps 1: 2400bps 2: 4800bps 3: 9600bps 4: 19200bps 5: 38400bps 6: 57600bps 7: 115200bps	3	0B02H
PB-03	Data format	0: (N,8,1)No check, data format:8, stop bit:1 1: (E,8,1)Even parity check, data format:8, stop bit:1 2: (O,8,1)Odd Parity check, data format:8, stop bit:1 3: (N,8,2)No check, data format:8, stop bit:2 4: (E,8,2)Even parity check, data format:8, stop bit:2 5: (O,8,2)Odd Parity check, data format:8, stop bit:2	3	0B03H
PB-04	Communication proportion setting	0.000~5.000	1.000	0B04H
PB-05	Communication response delay	0~0.500s	0.000s	0B05H
PB-06	Communication timeout failure time	0.0~100.0s	1.0s	0B06H
PB-07	Transmission response processing	0: Write response 1: Write no response	0	0B08H
PB-08	Master send selection	BIT0: The first set of transmission frame selection 0: Invalid 1: Run command setting 2: Master set frequency	0031	0B09H

PB-08	Master send selection	3: Master output frequency 4: Master upper limit frequency 5: Master set torque (reserved) 6: Master output torque 7: Limit of forward speed of master torque control (reserved) 8: Limit of reserved speed of master torque control (reserved) 9: PID set by the mater A:master feedback PID BIT1: Second set of transmission frame selection Ditto BIT2: The third set of transmission frame selection Ditto BIT3: Selection of the fourth set of transmission frames Ditto	0031	0B09H
PC Optimization Parameters				
Function Code	Parameter Name	Setting Range	Default	Address
PC-00	Carrier frequency characteristic selection	BIT0: 0: Temperature independent 1:Temperature related BIT1: 0:Asynchronous modulation 1: Synchronous modulation BIT2: 0: Random PWM invalid 1-A:Random PWM BIT3: Reserved	000	0C00H
PC-01	DPWM switchover frequency upper limit	0~15.00Hz	12.00Hz	0C01H
PC-02	Cooling fan control	0: The operation of the fan is just related to the temperature 1~A: The operation is related to the temperature, and during run, the fan is operating. Fixed air volume, maximum air volume above fifth gear	0	0C02H
PC-03	Rapid current limit enable	0~1	1	0C03H
PC-04	Dead zone compensation mode	0~2	1	0C04H
PC-05	Dynamic braking turn-on voltage	200~2000.0V	690V	0C05H
PC-06	Action voltage of energy consumption braking	0~100%	100%	0C06H
PC-07	Overvoltage threshold	0~2500.0V	810.0V	0C07H
PC-08	Undervoltage threshold	200.0~2000.0V	350V	0C08H

PC-09	Solution of undervoltage fault	0: Fault 1: Continue to operate within the allowable time of undervoltage recovery 2: Continue to operate after the power supply returns to normal	0	0C09H
PC-10	Allowable time of undervoltage recovery	0.1~60.0s	2.0s	0C0AH
PC-11	Restart method after power failure	0: Invalid 1: Valid	0	0C0BH
PC-12	Waiting time for restart after power failure	0.0~120.00s	3.00S	0C0CH
PD Internal control PLC Function and frequency parameters				
Function Code	Parameter Name	Setting Range	Default	Address
PD-00	Multi-frequency 1	0~100.0%	20.0%	0D00H
PD-01	Multi-frequency 2		40.0%	0D01H
PD-02	Multi-frequency 3		60.0%	0D02H
PD-03	Multi-frequency 4		80.0%	0D03H
PD-04	Multi-frequency 5		100.0%	0D04H
PD-05	Multi-frequency 6		80.0%	0D05H
PD-06	Multi-frequency 7		60.0%	0D06H
PD-07	Multi-frequency 8		40.0%	0D07H
PD-08	Multi-frequency 9		20.0%	0D08H
PD-09	Multi-frequency 10		40.0%	0D09H
PD-10	Multi-frequency 11		60.0%	0D0AH
PD-11	Multi-frequency 12		80.0%	0D0BH
PD-12	Multi-frequency 13		100.0%	0D0CH
PD-13	Multi-frequency 14		80.0%	0D0DH
PD-14	Multi-frequency 15		60.0%	0D0EH

PD-15	PLC running mode	BIT0: Circulation mode 0: Stop after the AC drive runs one cycle 1: Repeat after the AC drive runs one cycle 2: Keep final values after the AC drive runs one cycle BIT1: Chronograph unit 0: Second 1: Minute 2: Hour BIT2: Power down storage mode 0: No 1: Yes BIT3: Start-up mode 0: Rerun from stage one 1: Rerun from downtime 2: Continue operation with the rest of the downtime phase	0000	0D0FH
PD-16	Running time of PLC reference 1	0.0~6500.0 (s/m/h)	10.0	0D10H
PD-17	Running time of PLC reference 2	0.0~6500.0 (s/m/h)	10.0	0D11H
PD-18	Running time of PLC reference 3		10.0	0D12H
PD-19	Running time of PLC reference 4		10.0	0D13H
PD-20	Running time of PLC reference 5		10.0	0D14H
PD-21	Running time of PLC reference 6		10.0	0D15H
PD-22	Running time of PLC reference 7		10.0	0D16H
PD-23	Running time of PLC reference 8		10.0	0D17H
PD-24	Running time of PLC reference 9		10.0	0D18H
PD-25	Running time of PLC reference 10		10.0	0D19H
PD-26	Running time of PLC reference 11		10.0	0D1AH
PD-27	Running time of PLC reference 12		10.0	0D1BH
PD-28	Running time of PLC reference 13		10.0	0D1CH
PD-29	Running time of PLC reference 14		10.0	0D1DH
PD-30	Running time of PLC reference 15		10.0	0D1EH

PD-31	Running direction and acceleration/ deceleration time of PLC reference 1	BIT0: Operation direction of this section 0: Forward 1: Reverse BIT1: Acceleration and deceleration time of this section 0: Acceleration and deceleration time 1 1: Acceleration and deceleration time 2 2: Acceleration and deceleration time 3 3: Acceleration and deceleration time 4 BIT2: Reserved BIT3: Reserved	00	0D1FH
PD-32	Running direction and acceleration/ deceleration time of PLC reference 2		00	0D20H
PD-33	Running direction and acceleration/ deceleration time of PLC reference 3		00	0D21H
PD-34	Running direction and acceleration/ deceleration time of PLC reference 4		00	0D22H
PD-35	Running direction and acceleration/ deceleration time of PLC reference 5		00	0D23H
PD-36	Running direction and acceleration/ deceleration time of PLC reference 6		00	0D24H
PD-37	Running direction and acceleration/ deceleration time of PLC reference 7		00	0D25H
PD-38	Running direction and acceleration/ deceleration time of PLC reference 8		00	0D26H

PD-39	Running direction and acceleration/deceleration time of PLC reference 9	BIT0: Operation direction of this section 0: Forward 1: Reverse BIT1: Acceleration and deceleration time of this section 0: Acceleration and deceleration time 1 1: Acceleration and deceleration time 2 2: Acceleration and deceleration time 3 3: Acceleration and deceleration time 4 BIT2: Reserved BIT3: Reserved	00	0D27H	
PD-40	Running direction and acceleration/deceleration time of PLC reference 10		00	0D28H	
PD-41	Running direction and acceleration/deceleration time of PLC reference 11		00	0D29H	
PD-42	Running direction and acceleration/deceleration time of PLC reference 12		00	0D2AH	
PD-43	Running direction and acceleration/deceleration time of PLC reference 13		00	0D2BH	
PD-44	Running direction and acceleration/deceleration time of PLC reference 14		00	0D2CH	
PD-45	Running direction and acceleration/deceleration time of PLC reference 15		00	0D2DH	
PD-46	Swing frequency control		BIT0: Swing frequency setting mode 0: Invalid swing frequency control 1: Effective swing frequency control BIT1: Frequency swing input mode 0: Automatic input 1: Manual input BIT2: Swing control 0: Variable swing 1: Fixed swing BIT3: Reserved	00	0D2EH
PD-47	Preset frequency of swing frequency		0.00~maximum frequency	0.00Hz	0D2FH

PD-48	Preset frequency duration	0.00~650.00s	0.00s	0D30H
PD-49	Swing frequency amplitude	0.0~100.0%	0.0%	0D31H
PD-50	Jump frequency amplitude	0.0~50.0%	0.0%	0D32H
PD-51	Rise time of swing frequency	0.00~650.0s	5.0s	0D33H
PD-52	Falling time of swing frequency	0.00~650.0s	5.0s	0D34H
PF User-defined parameters				
Function Code	Parameter Name	Setting Range	Default	Address
PF-00	PF parameter group function	BIT0: 0: Normal display parameter group 1: Only display PF parameter group BIT1: 0: PF group function mode 1: PF group programming mode	0000	0F00H
PF-01	PF macro parameter selection	0: According to the user programming mode 1-100: Call the application macro defined by the manufacturer	0	0F01H
PF-02	PF parameter group length	3~66	18	0F02H
PF-03 ~ PF-67	Edit definition by user	0000~1EFF	0x0001	0F03H ~ 0F27H
A0 Torque control parameters				
Function Code	Parameter Name	Setting Range	Default	Address
A0-00	Control mode	0: Speed control 1: Torque control	0	1000H
A0-01	Torque setting source selection	BIT0: Main frequency source X selection(The full range of 1-7 option corresponds to A3-02) 0: Function code A3-02 setting 1: AI1 2: AI2 3: AI3 4: PULSE setting 5: Communication setting 6: MIN(AI1, AI2) 7: MAX(AI1, AI2) BIT1: Auxiliary frequency source Y selection (The full range of 1-7 option corresponds to A3-03) 0: Function code P5-11 setting 1: AI1 2: AI2 3: AI3 4: PULSE setting 5: Communication setting 6: MIN(AI1, AI2) 7: MAX(AI1, AI2) The full range of 1-7 option corresponds to P5-11	000	1000H

A0-01	Torque setting source selection	BIT 2: Main and frequency source selection 0: $X \times [A3-03]$ 1: $Y \times [A3-04]$ 2: $X \times [A3-03] + Y \times [A3-04]$ 3: $X \times [A3-03] - Y \times [A3-04]$ 4: $\text{MAX}\{X \times [A3-03], Y \times [A3-04]\}$ 5: $\text{MIN}\{X \times [A3-03], Y \times [A3-04]\}$ 6: Any non-zero value of the main frequency source X and auxiliary frequency source Y is valid, and the main frequency source X takes precedence.	000	1000H
A0-02	Torque digital setting in main frequency source X	-200~200.0%	100%	1002H
A0-03	Torque digital setting in auxiliary frequency source Y	-200~200.0%	100%	1003H
A0-04	Torque setting in main frequency source X Gain	0~5.000	1.000	1004H
A0-05	Torque setting in auxiliary frequency source Y Gain	0~5.000	1.000	1005H
A0-06	Torque given filter time	0.0~10.00	0.11	1006H
A0-07 ~ A0-09	Reserved	-	-	1007H ~ 1009H
A0-10	Forward maximum frequency in torque control	0.0Hz~maximum frequency	50.00Hz	100AH
A0-11	Reverse maximum frequency in torque control	0.0Hz~maximum frequency	50.00Hz	100BH
A0-12	Acceleration time in torque control	0.00~100.00s	0.00s	100CH
A0-13	Deceleration time in torque control	0.00~100.00s	0.00s	100DH
A1 Constant Pressure Water Supply Parameters				
Function Code	Parameter Name	Setting Range	Default	Address
A1-00	Multiple pump control	BIT0: 0: Multiple pump control is invalid 1: Frequency transform pump fix, no timing shift 2: Frequency transform pump fix with timing shift 3: Frequency transform pump circulating, no timing shift	0110	1100H

A1-00	Multiple pump control	4: Frequency transform pump circulating, has timing shift BIT1: Quantity of pump BIT2: 0: Start first then stop (suitable to unequal pump power) 1: Start first then stop first (suitable to equal pump power) BIT3: 0: The time unit of timed rotation is 0.1 hours 1: The time unit of timed rotation is 0.1 minutes	0110	1100H
A1-01	Add pump given increment 1	0.0~100.0%	0.0%	1101H
A1-02	Add pump given increment 2	0.0~100.0%	0.0%	1102H
A1-03	Add pump given increment 3	0.0~100.0%	0.0%	1103H
A1-04	Motor connect-in judge function	BIT0: Valid pump judge invalid 0: Invalid 1: By S terminal invalid 2: Decided by A01-05 setting BIT1: Reserved BIT2: Reserved BIT3: Reserved	2	1104H
A1-05	Motor connect-in setting	0: This motor and system is disconnect 1: This motor connect-in system	1111	1105H
A1-06	Timing rotation time	0.1~6000.0	0.1h	1106H
A1-07	Timing rotation frequency limit	0.00~maximum frequency	50.00Hz	1107H
A1-08	Timing rotation the quantity of rest motors	1~3	1	1108H
A1-09	Add pump frequency 1	0.00~maximum frequency	48.00Hz	1109H
A1-10	Reduce pump frequency 1	0.00~A1-09	25.00Hz	110AH
A1-11	Add pump frequency 2	0.00~maximum frequency	48.00Hz	110BH
A1-12	Reduce pump frequency 2	0.00~A1-11	25.00Hz	110CH
A1-13	Add pump frequency 3	0.00~maximum frequency	48.00Hz	110DH
A1-14	Reduce pump frequency 2	0.00~A1-13	25.00Hz	110EH
A1-15	Add pump delay time	0~3600.0s	5.0S	110FH
A1-16	Reduce pump delay time	0~3600.0s	3.0S	1110H
A1-17	Industry frequency switch lock time	0.02~10.00	0.20s	1111H

A1-18	Industry frequency switch frequency	0.00~maximum frequency	50.00Hz	1112H
A1-19	Fixed pump troubleshooting	0 to 2 BIT0: 0:Emergency stop, report failure, all auxiliary pumps stop working. 1:Emergency stop, report failure, auxiliary pump maintains the status quo 2:Only alarm, the system continues to run BIT1:Reserved BIT2: Reserved BIT3:Reserved	0	1113H
A1-20 ~ A1-25	Reserved	-	-	1114H ~ 1119H
U Monitoring Parameters				
Function Code	Parameter Name	Setting Range	Default	Address
U-00	Set frequency	-	-	2110H
U-01	Output frequency	-	-	2111H
U-02	Output current	-	-	2112H
U-03	Output voltage	-	-	2113H
U-04	Input voltage	-	-	2114H
U-05	Mechanical speed	-	-	2115H
U-06	Bus voltage	-	-	2116H
U-07	Output power	-	-	2117H
U-08	Target torque	-	-	2118H
U-09	Output torque	-	-	2119H
U-10	PID setting	-	-	211AH
U-11	PID feedback	-	-	211BH
U-12	AI1 input value	-	-	211CH
U-13	AI2 input value	-	-	211DH
U-14	HS input value	-	-	211EH
U-15	Counter count value	-	-	211FH
U-16	AI3 input value	-	-	2120H
U-17	Terminal S Status	-	-	2121H
U-18	Terminal Y Status	-	-	2122H
U-19	A01 output value	-	-	2123H
U-20	A02 output value	-	-	2124H
U-21	HY output value	-	-	2125H
U-22	Reserved	-	-	2126H
U-23	Model temperature	-	-	2127H
U-24	Output excitation	-	-	2128H
U-25	Power factor	-	-	2129H
U-26	Power-on time	-	-	212AH
U-27	power-on operation time	-	-	212BH
U-28	Accumulated time	-	-	212CH

U-29	AC drive running state	-	-	212DH
U-30	Maximum current	-	-	212EH
U-31	Maximum voltage	-	-	212FH
U-32	Maximum temperature of this operation	-	-	2130H
U-33	Miniamum voltage	-	-	2131H
U-34	Rated power of AC drive	-	-	2132H
U-35	Rated voltage of AC drive	-	-	2133H
U-36	Rated current of AC drive	-	-	2134H
U-37	AC version	-	-	2135H
U-38	MC version	-	-	2136H
U-39	Communication frequency	-	-	2137H
U-40	Main frequency X display	-	-	2138H
U-41	Auxiliary frequency Y display	-	-	2139H
U-42	Remaining time	-	-	213AH
U-43	Target voltage upon V/F separation	-	-	213BH
U-44	Output voltage upon V/F separation	-	-	213CH
U-45	PG feedback value	-	-	213DH
U-46	Linear speed	-	-	213EH
U-47	PM rotor position	-	-	213FH
U-48	Resolver position	-	-	2140H
U-49	ABZ position	-	-	2141H
U-50	Phase Z counting	-	-	2142H
U-51	Communication sending value	-	-	2143H
U-52	Communication receiving value	-	-	2144H
U-53	Motor temperature	-	-	2145H
U-54	Multiple pumps control	-	-	2146H

Press PRG key for 2 seconds continuously to enter the U monitoring parameter group item

10. Standard wiring diagram

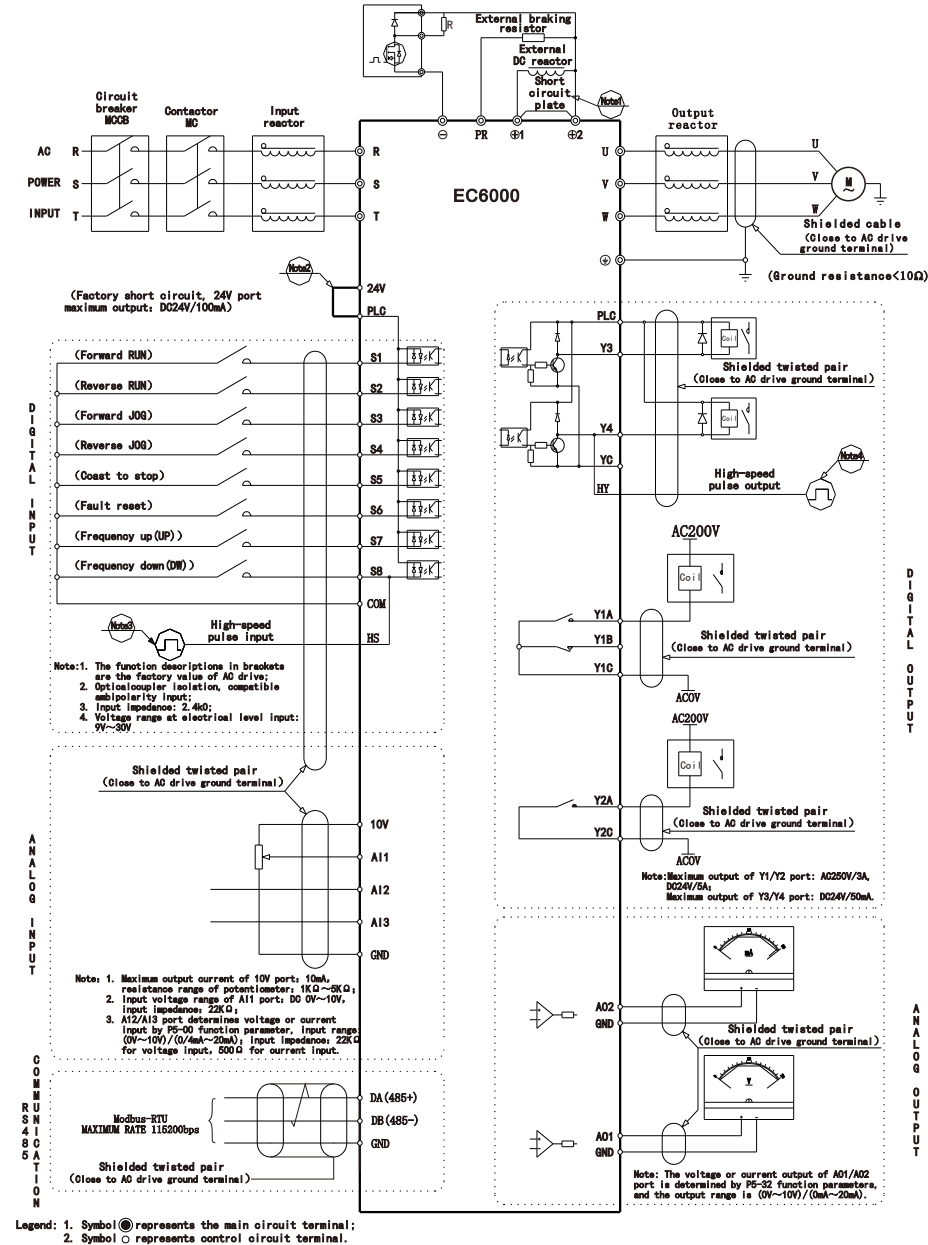

Note: 1. When installing DC reactor, be sure to remove the short connector between terminals $\oplus 1$ and $\oplus 2$; EC6020 and below structure without $\oplus 2$ terminal.

2. No PR terminal for EC6060 and above.
3. The internal power supply (24V port) or external power supply (PLC port) can be selected for S1~S8 port bias voltage, and the factory value 24V port and PLC port are short circuited;
4. Port S8 is restricted by function parameter P5-00, which can be used as high-speed pulse input channel with maximum input frequency of 50KHz;
5. Port Y4 is restricted by function parameter P5-32, which can be used as high-speed pulse input channel with maximum input frequency of 50KHz.
6. SP switch pin corresponding legend:



When the Y3 or Y4 terminals use the +24V voltage of PLC and com, the SW1 dial switch is down.
 The resistance of the communication end is down to connect.

11. Warranty Service



Manufacturer of high quality inverter

Warranty Card

User Name			
User Address			
User Contact		Tel	
Specification		Number	
Distributor			
Contacts		Date of delivery	

ZHE JIANG EACN ELECTRONIC TECHNOLOGY CO.,LTD.
 Address: No.1 Jinhe Road, Qinshan Street, Haiyan County, Jiaxing City, Zhejiang Province .
 Website: www.eacon.cn
 E-mail: overseas@eacon.cc